

(DA) **Monteringsvejledning**

(EN) **Assembly instructions**

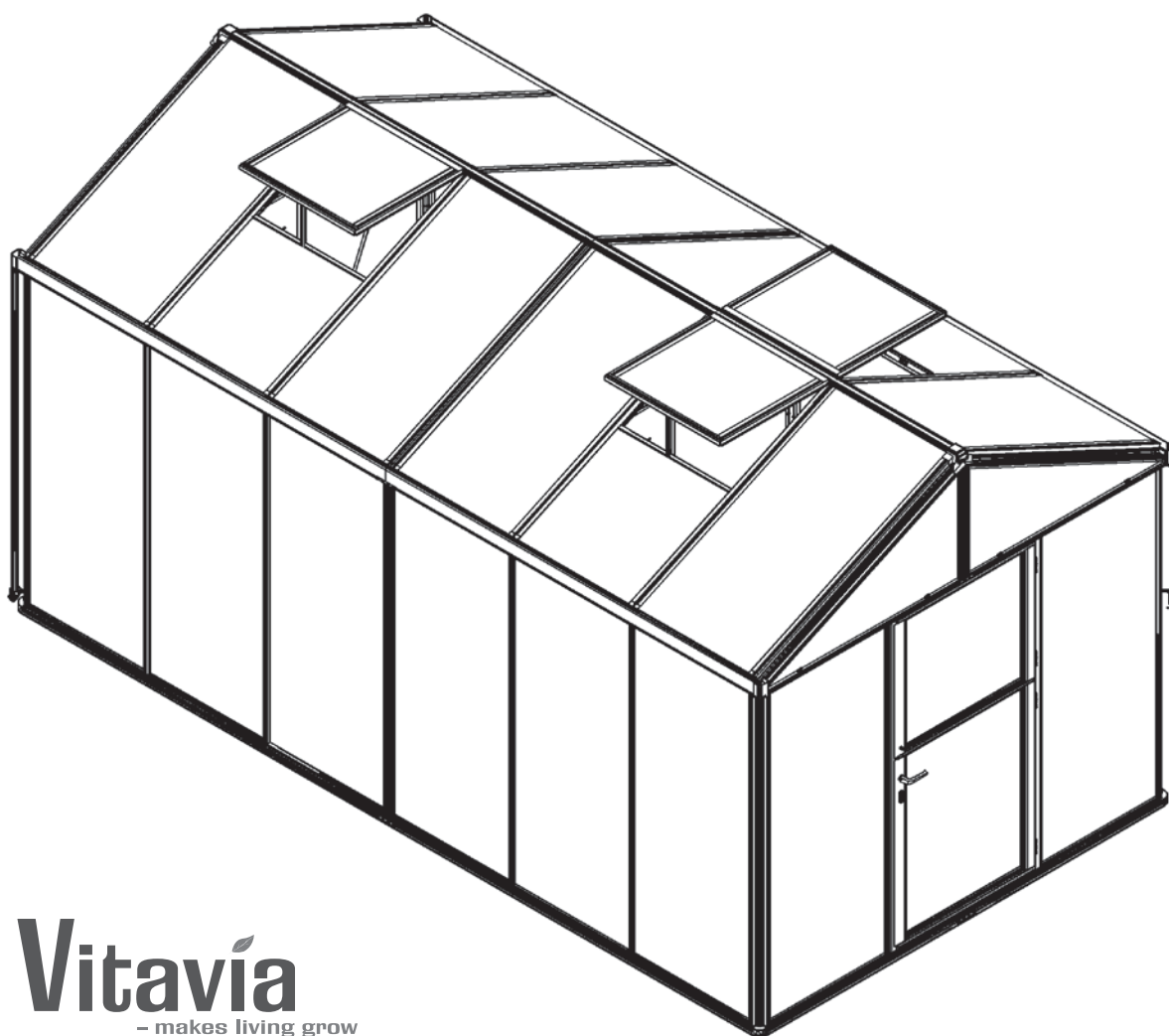

Vitavia
- makes living grow

ZEUS 2
8100, 10000, 11900, 13800, 15700

Kære kunde,

Tak fordi De har valgt et Vitavia produkt. Vi er overbevist om, at De vil få megen glæde af og mange gode stunder i Deres drivhus.



Læs venligst hele denne monteringsvejledning, inden samling og opstilling af drivhuset påbegyndes.

• Indhold / symboler	S.2
• Anbefalinger / gode råd	S.3
• Sikkerhedshenvisninger	S.4
• Vedligeholdelse og pleje	S.5
• Stykliste oversigt	S.6
• Stykliste pakke 1-1	S. 7-9
• Stykliste pakke 1-2	S. 10-18
• Stykliste pakke 2	S. 19-23
• Stykliste pakke 3	S. 24-28
• Stykliste pakke 4	S. 29-33
• Stykliste pakke 5 - ventilationsvinduer	S. 34-35
• Fundament / sokkel	S. 36-37
Samling og montering	
• Trin 1 Bundramme og hjørnestolper	S. 38-39
• Trin 2 Midterprofil og tagrem	S. 40-41
• Trin 3 Mellemprofiler	S. 42-43
• Trin 4 Tag	S. 44-47
• Trin 5 Ventilationsvinduer	S. 48-49
• Trin 6 Dør	S. 50-53
• Trin 7 Isætning af glas / polycarbonatplader	S. 54-63
• Trin 8 Færdiggørelse	S. 64-65
• Trin 9 Nedløbsrør	S. 66-67



Tegninger med enkelramme er set indefra.

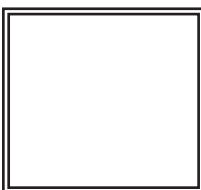

Tegninger med dobbelramme er set udefra.



**NB!: Vigtigt tip!
Bemærk venligst!**

Bemærk: Vi anvender betegnelsen ”kode” som synonym for ”artikelnummer” eller ”del nr.”
Kodenumre er angivet som et 4-cifret tal umiddelbart efter navnet på delen.
Henvisninger til tabeller og illustrationer er anført som tal indføjet i parenteser.



De bør altid bruge handsker, når De arbejder med polycarbonatplader eller glas. Skarpe kanter kan forårsage skader. Der kan også forekomme skarpe kanter på kanter og hjørner på aluminiumsprofiler. Her bør De også bære handsker. Ved isætning af glas bør De også anvende beskyttelsesbriller, sikkerhedssko og hovedbeskyttelse (sikkerhedshjelm). Itugået glas udgør en sikkerhedsrisiko og bør bortskaffes med forsigtighed.

Bemærk venligst!

Dette produkt er konstrueret som et drivhus beregnet til planteavl og er som sådan ikke konstrueret til at være helt tæt, da det er nødvendigt med udluftning bl.a. for at undgå kondensdannelse.

Såfremt De ønsker at anvende drivhuset som et ”uderum/stue” eller lignende, gør vi udtrykkeligt opmærksom på, at drivhuset ikke er 100 % vandtæt, og at vi ikke påtager os noget ansvar for eventuelle skader på løsøre el. lign., der er anbragt i drivhuset.

Til montage af dette produkt kræves min. 2 personer.

Skulle De få problemer med drivhusmontagen eller glasisætning, bedes De kontakte Deres forhandler eller vor kundeservice på opj@opj.dk

Anvend ikke vold.

Placering

Vælg et solrigt sted, hvor der er mest muligt læ. Undgå at placere drivhuset på steder, hvor der kan opstå turbulens pga. nærtstående bygninger.

Vigtigt

Før De begynder at samle Deres drivhus, kontroller venligst efter indholdsfortegnelsen, at alle dele er medleveret. Tag de enkelte bundter ud af kassen for bedre at kunne kontrollere indholdet. Undgå så vidt muligt at åbne delpakkerne, før De når til det pågældende punkt i vejledningen.

Numrene på bundterne stemmer overens med nummereringen i monteringsvejledningen.

Det er vigtigt ikke at blande åbnede bundter.

Hvis der mangler noget, kontakt venligst Deres forhandler.

Såfremt De mener, at en del ikke passer, må De under ingen omstændigheder begynde at tilpasse denne del ved at bore eller save i aluminiumsprofilerne. Kontakt i stedet vor kundeservice på opj@opj.dk, der vil hjælpe Dem videre.

Vi forbeholder os ret til at foretage tekniske ændringer af produktet og dets specifikationer, hvilket kan medføre ændringer i vejledningerne.

På vor hjemmeside vil De altid kunne finde den nyeste udgave af monteringsvejledningen. Såfremt denne måtte afvige væsentligt fra Deres produkt, er De velkommen til at kontakte vor kundeservice på opj@opj.dk. De kan identificere Deres udgave af vejledningen ved hjælp af det nummer, der er anført nederst på alle sider i vejledningen.

Nødvendigt værktøj (indgår ikke i leverancen):

Skruetrækker (stjerne PH2 og PZ2), Akku-boremaskine med moment, Ø 20 mm bor, 1x10 mm fastnøgle, 1x10 mm gaffelnøgle, 1-2 trappestiger 1,80 m, 1 målebånd/tommestok, 1 vaterpas, 1 hobbykniv, 1 gummihammer, 1 skævbider

- **De bør altid bruge handsker, når De arbejder med polycarbonatplader eller glas. Skarpe kanter kan forårsage skader. Der kan også forekomme skarpe kanter på kanter og hjørner på aluminiumsprofiler. Her bør De også bære handsker. Ved isætning af glas bør De også anvende beskyttelsesbriller, sikkerhedssko og hovedbeskyttelse (sikkerhedshjelm). Itugået glas udgør en sikkerhedsrisiko og bør bortskaffes med forsigtighed.**
- **NB! Udvis forsigtighed ved glasmontage. Glasset kan splintre under monteringen.**
- **Bær gerne sikkerhedsbriller, medens glasset monteres.**
- **Samling af drivhuset og montering af glas bør ikke foretages i stærk blæst eller storm.**
- **Efter ca. 2 uger efterspændes alle bolte uden at overspænde disse.**



Læs hele monteringsvejledningen, inden samlingen af drivhuset påbegyndes.



Vedligeholdelse

Drivhuset bør lejlighedsvis rengøres grundigt med et mildt rengøringsmiddel. Glas-set kan rengøres med et hvilket som helst rengøringsmiddel, der ikke skader aluminiumsprofiler eller glasholdere og clips, f.eks. Vitavia drivhusrens eller brun sæbe. Test eventuelt på et mindre område, hvis De er i tvivl.

Dørskinnerne bør regelmæssigt rengøres og smøres med stearin/grafitolie.

Ved snefald fjernes sneen fra taget, således at der ikke opstår risiko for skader som følge af snebelastningen af glas og profiler. Ved kraftigt snefald og ved skiftevis tø- og frostvejr skal sne fjernes hurtigst muligt fra taget.

Ved risiko for kraftigt snefald understøttes tagryggen med en stolpe eller lign.

Ved kraftig blæst skal alle vinduer og døre lukkes. Afmonter / deaktiver eventuelle automatiske vinduesåbnere.



Anmærkning

Vi anbefaler, at De sørger for, at Deres husforsikring også dækker Deres drivhus. Overhold alle byggevedtægter. Kontakt Teknisk Forvaltning i Deres kommune, hvis De er i tvivl.

Typebetegnelsen skal De bruge ved bestilling af evt. reservedele, så opbevar venligst montagevejledningen til senere brug.











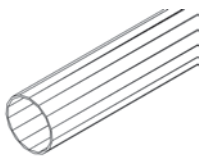

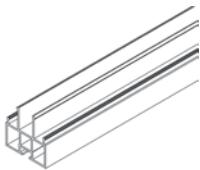
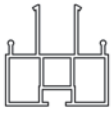
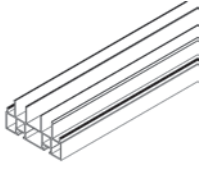
Skulle De få problemer med drivhusmontagen eller glasisætning, bedes De kontakte Deres forhandler eller vor kundeservice på opj@opj.dk

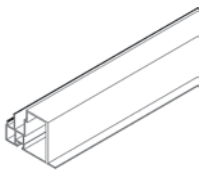
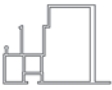
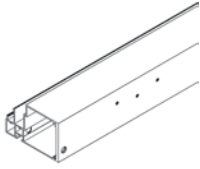
Følg de beskrevne arbejdsgange meget omhyggeligt. Såfremt De mener, at der skulle være fejl ved produktet eller i vejledningen, eller hvis noget er uklart, er De velkommen til at kontakte os på opj@opj.dk Vi forsøger løbende at opdatere vore vejledninger og modtager gerne input via e-mail.

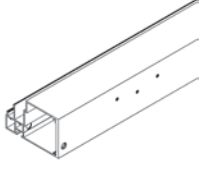
Kontroller først om De har modtaget det korrekte antal delpakker passende til Deres model ved hjælp af nedenstående oversigttabel

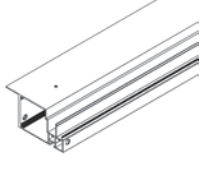













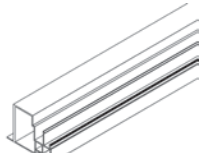

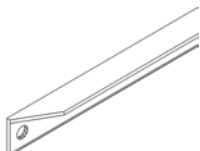

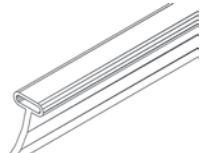
Model	Pakke 1-1	Pakke 1-2	Pakke 2	Pakke 3	Pakke 4	Pakke 5
8100	1	1	2			
10000	1	1	1	1		
11900	1	1		2		1
13800	1	1		1	1	1
15700	1	1			2	1

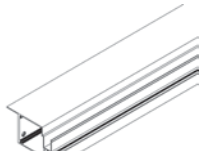

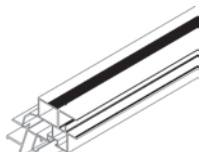
Stykliste

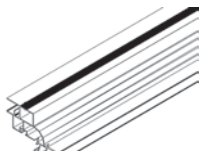
Pakke 1-1					Antal stk. / Model					
Kode nr.	Artikel	Montage- trin	Længde i mm	Antal i delpakke	8100	10000	11900	13800	15700	Profil
1415		9	1750	2	2	2	2	2	2	
6090		7b 7c	56000	1	77000	85500	94000	103000	112000	
7005		3	1775	2	6	8	10	12	14	
7006		2	1775	3	3	3	3	3	3	
7014		2	1775	1	1	1	1	1	1	
7015		6b	1000	1	1	1	1	1	1	
7017		6a	717	1	1	1	1	1	1	
7018		6a	717	1	1	1	1	1	1	
7030		7b	1793	2	2	2	2	2	2	

ZEUS 2

Stykliste

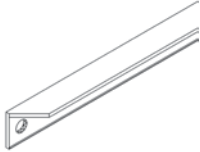









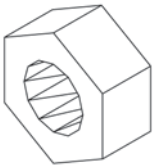
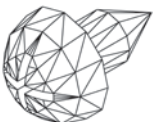

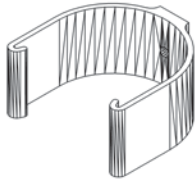
Kode nr.	Pakke 1-1				Antal stk. / Model					Profil
	Artikel	Montage- trin	Længde i mm	Antal i delpakke	8100	10000	11900	13800	15700	
7032		7b	1793	2	6	8	10	12	14	
7033		7b	1793	14	14	14	14	14	14	
7045		2	1775	1	1	1	1	1	1	
7069		3	1924	4	4	4	4	4	4	
7083		6a 6b	900	2	2	2	2	2	2	
7216		6b	1000	1	1	1	1	1	1	
7237		4a	1362	2	2	2	2	2	2	
7238		4a	1362	2	2	2	2	2	2	
7269		3	1926	4	4	4	4	4	4	

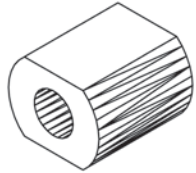
Pakke 1-1					Antal stk. / Model					
Kode nr.	Artikel	Montage- trin	Længde i mm	Antal i delpakke	8100	10000	11900	13800	15700	Profil
7295		4a	1531.5	4	4	4	4	4	4	

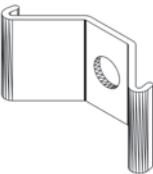

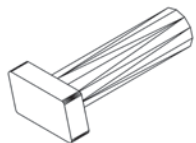
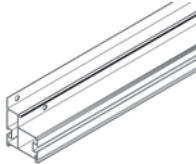

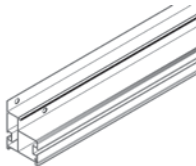





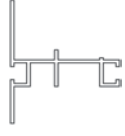
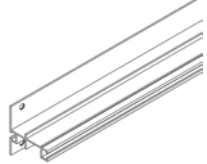
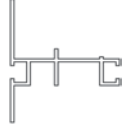
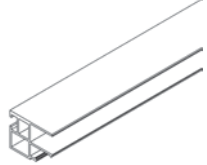

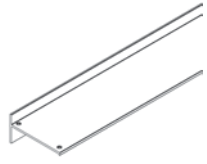
Stykliste

ZEUS 2

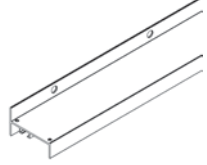
Styklister

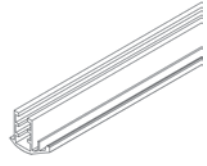



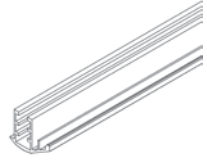
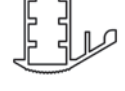

Kode nr.	Pakke 1-2				Antal stk. / Model					Profil
	Artikel	Montage- trin	Længde i mm	Antal i delpakke	8100	10000	11900	13800	15700	
1002		9	M6	2	2	2	2	2	2	
1006		4b 5 6a 6b 9	3.5x6	22	32	32	38	38	38	
1402		9	36	2	2	2	2	2	2	
1403		9	20	2	2	2	2	2	2	
1405		9	15	2	2	2	2	2	2	
1409		9	20	2	2	2	2	2	2	
1412		9	M6x22	2	2	2	2	2	2	
7003		1	1230	2	2	2	2	2	2	
7004		1	1230	2	2	2	2	2	2	

Stykliste

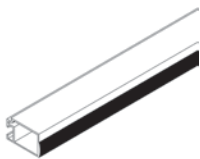
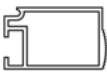

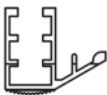

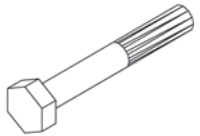
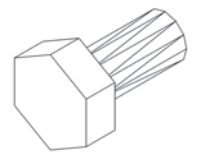
Pakke 1-2					Antal stk. / Model					
Kode nr.	Artikel	Montage- trin	Længde i mm	Antal i delpakke	8100	10000	11900	13800	15700	Profil
7010		2	1229.5	2	2	2	2	2	2	
7011		2	1229.5	2	2	2	2	2	2	
7022		6a 6b	708	4	4	4	4	4	4	
7023		6b	850	1	1	1	1	1	1	
7024		6a	850	1	1	1	1	1	1	
7025		6a 6b	850	2	2	2	2	2	2	
7031		7c	996	2	2	2	2	2	2	
7034		7b 7c	733	8	16	18	20	22	24	
7035		7c	713	2	2	2	2	2	2	

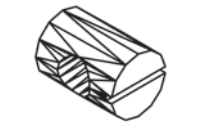
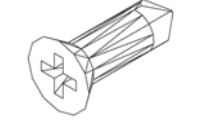
ZEUS 2

Stykliste

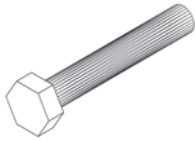
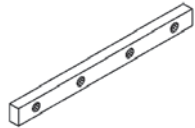

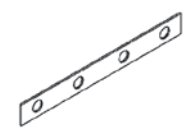
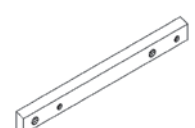
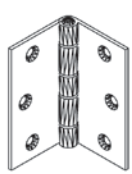
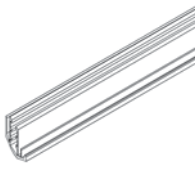
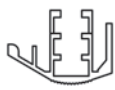
Pakke 1-2					Antal stk. / Model					
Kode nr.	Artikel	Montage- trin	Længde i mm	Antal i delpakke	8100	10000	11900	13800	15700	Profil
7036		7b	922	1	1	1	1	1	1	
7044		7b	443	2	2	2	2	2	2	
7048		4b	M6x80	2	0	1	2	2	2	
7050		7b	M6x42	92	126	138	150	162	174	
7052		1, 2 3, 4 5, 6 7a	M6x12	104	154	176	202	224	246	
7053		1, 2 3, 4 5, 6 7, 8	M6x4	223	307	341	379	413	447	
7054		4b 6	M6x100	8	12	12	14	14	14	
7055		4b 6	M6x10 x14	8	12	12	14	14	14	
7056		8	3.9x13	4	4	4	4	4	4	

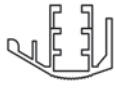
Stykliste

Pakke 1-2					Antal stk. / Model					
Kode nr.	Artikel	Montage- trin	Længde i mm	Antal i delpakke	8100	10000	11900	13800	15700	Profil
7058		7c	M6x38	22	22	22	22	22	22	
7061		1 2 4a 7a	117	9	15	15	15	15	15	
7062		4	235	4	6	7	8	9	10	
7063		3	255	4	8	10	12	14	16	
7064		1 2 4a 7a	117	5	11	11	11	11	11	
7065		4a	140	2	2	2	2	2	2	
7066		6	75	4	4	4	4	4	4	
7074		7b	1369	2	2	2	2	2	2	
7075		7b	1369	2	2	2	2	2	2	

ZEUS 2

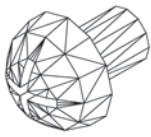
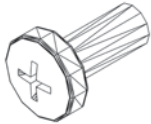
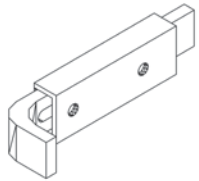
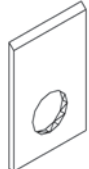
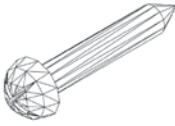
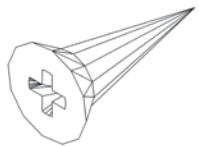
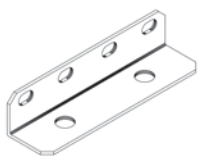
Stykliste

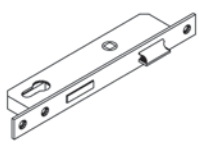
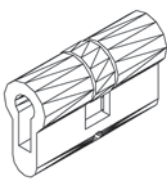



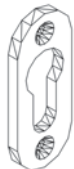
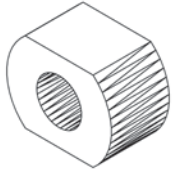



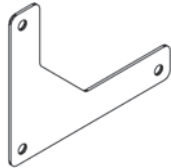
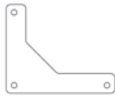
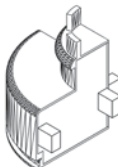
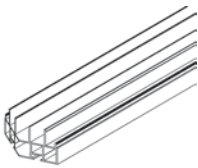

Pakke 1-2					Antal stk. / Model					
Kode nr.	Artikel	Montage- trin	Længde i mm	Antal i delpakke	8100	10000	11900	13800	15700	Profil
7080		1 2 4a 7a	M6x8	36	60	60	60	60	60	
7081		4a	M5x13	4	4	4	4	4	4	
7085		6a	95	1	1	1	1	1	1	
7086		6b	23	1	1	1	1	1	1	
7087		6a	5x30	2	2	2	2	2	2	
7088		6 8	3.9x13	32	30	30	30	30	30	
7095		1	117	4	4	4	4	4	4	
7100		6b	244	1	1	1	1	1	1	
7101		6b	62	1	1	1	1	1	1	

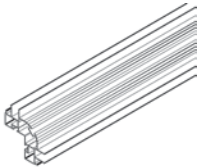
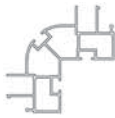
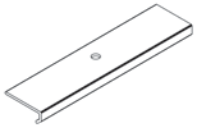
Stykliste

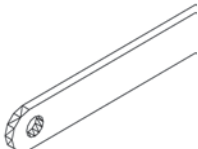

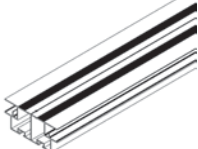

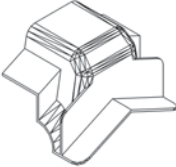

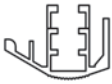
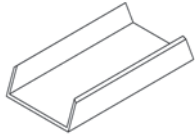

Pakke 1-2					Antal stk. / Model					
Kode nr.	Artikel	Montage- trin	Længde i mm	Antal i delpakke	8100	10000	11900	13800	15700	Profil
7102		6b	M5x35	1	1	1	1	1	1	
7103		6b	65	2	2	2	2	2	2	
7104		6b	125	2	2	2	2	2	2	
7106		6b	Ø 27	2	2	2	2	2	2	
7107		6b	100	1	1	1	1	1	1	
7108		6b	4.7x8	2	2	2	2	2	2	
7111		8	35	1	1	1	1	1	1	
7112		8	8	1	1	1	1	1	1	
7113		8	100	1	1	1	1	1	1	

ZEUS 2

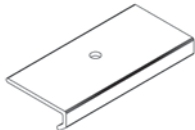
Styklister



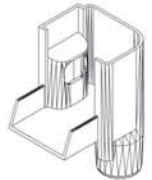
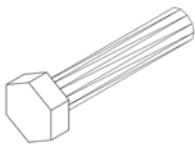
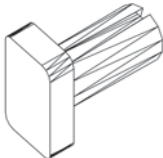
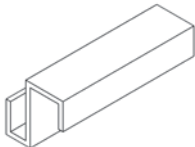



Kode nr.	Artikel	Pakke 1-2			Antal stk. / Model					Profil
		Montage- trin	Længde i mm	Antal i delpakke	8100	10000	11900	13800	15700	
7114		6	138	4	4	4	4	4	4	
7200		1	62	4	4	4	4	4	4	
7219		3	569.5	2	2	2	2	2	2	
7236		1	1775	4	4	4	4	4	4	
7240		7a	88	2	2	2	2	2	2	
7249		4b	1251	1	3	4	5	6	7	
7256		4a	1356	2	2	2	2	2	2	
7266		8	91	2	2	2	2	2	2	
7276		7b	582	2	2	2	2	2	2	

Stykliste

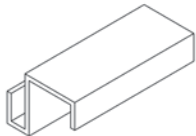

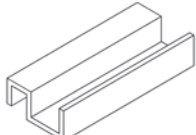

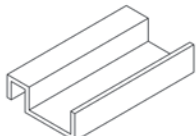



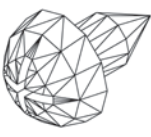
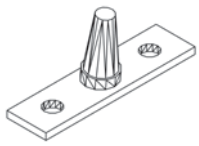

Pakke 1-2					Antal stk. / Model					
Kode nr.	Artikel	Montage- trin	Længde i mm	Antal i delpakke	8100	10000	11900	13800	15700	Profil
7277		7b	582	2	2	2	2	2	2	
7292		7a	100	2	2	2	2	2	2	
7342		7a	45	4	4	4	4	4	4	
7349		7a 8	3.9x10	6	38	46	56	64	72	
7370		8	71	2	2	2	2	2	2	
7371		8	71	2	2	2	2	2	2	
7390		7b	M6x30	4	4	4	4	4	4	
7399		8	M6x12	1	1	1	1	1	1	
7406		7b	30	6	14	16	18	20	22	

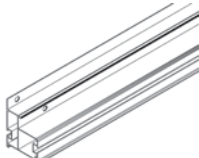
ZEUS 2

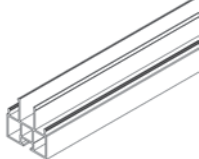
Stykliste



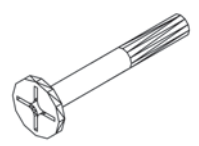
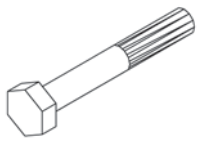

Pakke 1-2					Antal stk. / Model					
Kode nr.	Artikel	Montage- trin	Længde i mm	Antal i delpakke	8100	10000	11900	13800	15700	Profil
7407		7b	30	6	14	16	18	20	22	
7408		7b	30	8	8	8	8	8	8	
7409		7b	30	8	8	8	8	8	8	

Stykliste



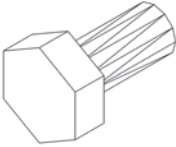

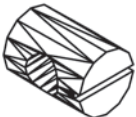
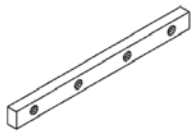

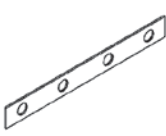
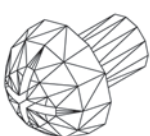



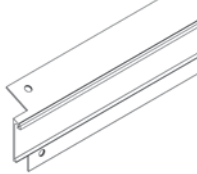

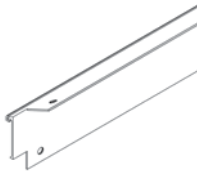

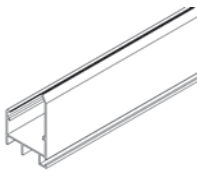
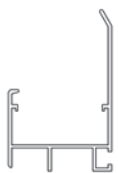
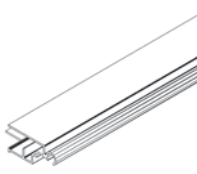
Pakke 2					Antal stk. / Model					
Kode nr.	Artikel	Montage- trin	Længde i mm	Antal i delpakke	8100	10000	11900	13800	15700	Profil
1006		4b 5 6a 6b 9	3.5x6	6	32	32	38	38	38	
6056		4b	46	2	4	4	6	6	6	
6090		7b 7c	10500	1	77000	85500	94000	103000	112000	
7001		1	1520	2	4	2	-	-	-	
7005		3	1775	2	6	8	10	12	14	
7032		7b	1793	2	6	8	10	12	14	
7034		7b 7c	733	4	16	18	20	22	24	
7047		4b	M6x48	1	2	4	4	6	8	
7050		7b	M6x42	19	126	138	150	162	174	

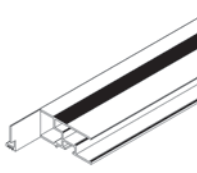
ZEUS 2

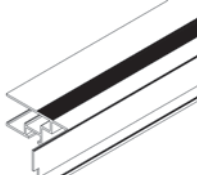
Styklister

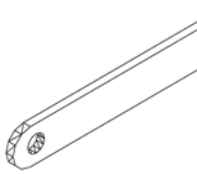

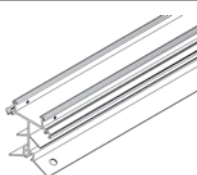







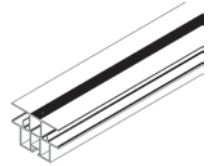
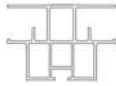
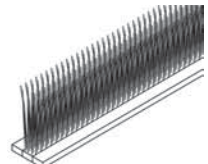

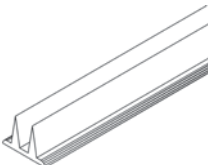

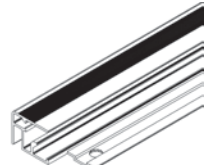
Pakke 2					Antal stk. / Model					
Kode nr.	Artikel	Montage- trin	Længde i mm	Antal i delpakke	8100	10000	11900	13800	15700	Profil
7052		1, 2 3, 4 5, 6 7a	M6x12	30	154	176	202	224	246	
7053		1, 2 3, 4 5, 6 7, 8	M6x4	49	307	341	379	413	447	
7054		4b 6	M6x100	2	12	12	14	14	14	
7055		4b 6	M6x10 x14	2	12	12	14	14	14	
7061		1 2 4a 7a	117	3	15	15	15	15	15	
7062		4	235	1	6	7	8	9	10	
7063		3	255	2	8	10	12	14	16	
7064		1 2 4a 7a	117	3	11	11	11	11	11	
7080		1 2 4a 7a	M6x8	12	60	60	60	60	60	

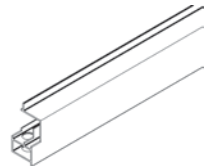
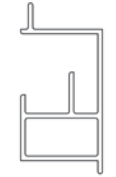
Stykliste



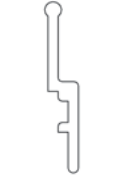



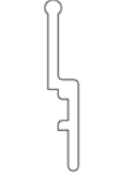

Pakke 2					Antal stk. / Model					
Kode nr.	Artikel	Montage- trin	Længde i mm	Antal i delpakke	8100	10000	11900	13800	15700	Profil
7090		5	324	1	2	2	3	3	3	
7201		2	1539	1	2	1	-	-	-	
7202		2	1539	1	2	1	-	-	-	
7213		7a	1539	2	4	2	-	-	-	
7244		5	713	1	2	2	3	3	3	
7247 (7291)		5	674	1	2	2	3	3	3	
7248 (7291)		5	674	1	2	2	3	3	3	
7249		4b	1251	1	3	4	5	6	7	
7250		4a	1520	1	2	1	-	-	-	

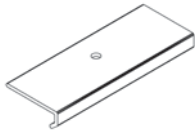
ZEUS 2

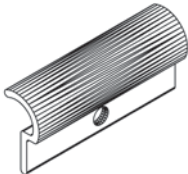

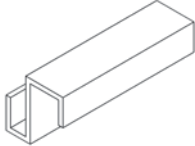

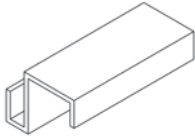



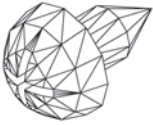
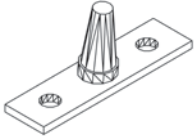

Stykliste



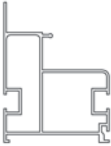
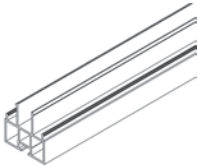

Pakke 2					Antal stk. / Model					
Kode nr.	Artikel	Montage- trin	Længde i mm	Antal i delpakke	8100	10000	11900	13800	15700	Profil
7255		4b	1356	2	4	6	8	10	12	
7257		4a	1520	2	4	2	-	-	-	
7291 (7247 & 7248)		5	674	2	4	4	6	6	6	
7293		5	713	1	2	2	3	3	3	
7294		4b	708	1	2	2	3	3	3	
7296		7a	707	4	8	10	12	14	16	
7297		7a	687	4	8	10	12	14	16	
7298		7a*	30	4	8*	10*	12*	14*	16*	
7299		7a*	30	4	8*	10*	12*	14*	16*	

Styklister

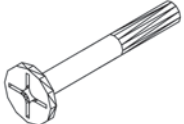
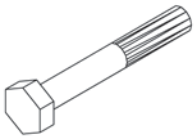

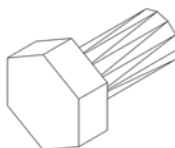

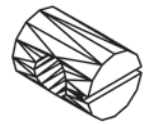
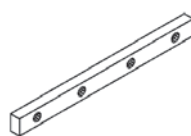

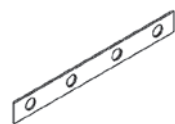
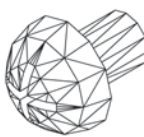



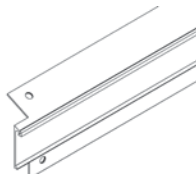

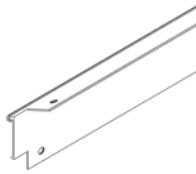

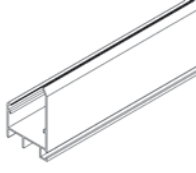
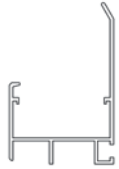
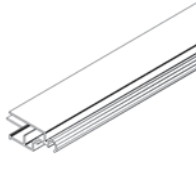
Pakke 2					Antal stk. / Model					
Kode nr.	Artikel	Montage- trin	Længde i mm	Antal i delpakke	8100	10000	11900	13800	15700	Profil
7343		7a	56	2	4	6	8	10	12	
7349		7a 8	3.9x10	16	38	46	56	64	72	
7369		8	30	2	4	4	6	6	6	
7406		7b	30	4	14	16	18	20	22	
7407		7b	30	4	14	16	18	20	22	

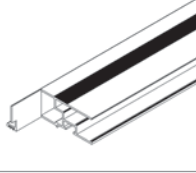
Styklister

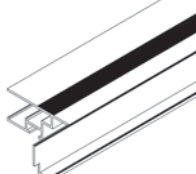

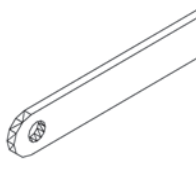

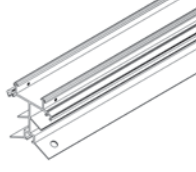





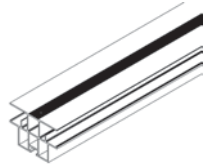
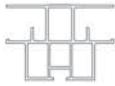
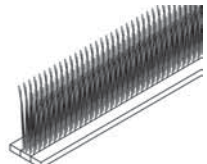

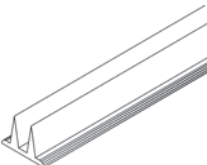
Pakke 3					Antal stk. / Model					
Kode nr.	Artikel	Montage- trin	Længde i mm	Antal i delpakke	8100	10000	11900	13800	15700	Profil
1006		4b 5 6a 6b 9	3.5x6	6	32	32	38	38	38	
6056		4b	46	2	4	4	6	6	6	
6090		7b 7c	19000	1	77000	85500	94000	103000	112000	
7002		1	2264	2	-	2	4	2	-	
7005		3	1775	4	6	8	10	12	14	
7032		7b	1793	4	6	8	10	12	14	
7034		7b 7c	733	6	16	18	20	22	24	
7047		4b	M6x48	3	2	4	4	6	8	
7050		7b	M6x42	31	126	138	150	162	174	

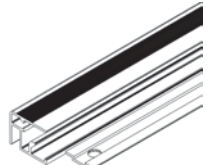
Pakke 3					Antal stk. / Model					
Kode nr.	Artikel	Montage- trin	Længde i mm	Antal i delpakke	8100	10000	11900	13800	15700	Profil
7052		1, 2 3, 4 5, 6 7a	M6x12	52	154	176	202	224	246	
7053		1, 2 3, 4 5, 6 7, 8	M6x4	83	307	341	379	413	447	
7054		4b 6	M6x100	2	12	12	14	14	14	
7055		4b 6	M6x10 x14	2	12	12	14	14	14	
7061		1 2 4a 7a	117	3	15	15	15	15	15	
7062		4	235	2	6	7	8	9	10	
7063		3	255	4	8	10	12	14	16	
7064		1 2 4a 7a	117	3	11	11	11	11	11	
7080		1 2 4a 7a	M6x8	12	60	60	60	60	60	

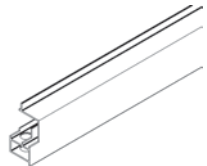
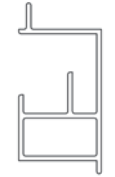
Styklister

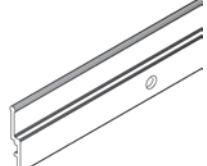
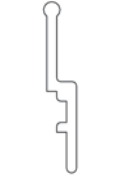



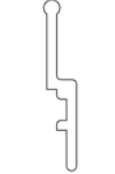



Pakke 3					Antal stk. / Model					
Kode nr.	Artikel	Montage- trin	Længde i mm	Antal i delpakke	8100	10000	11900	13800	15700	Profil
7090		5	324	1	2	2	3	3	3	
7203		2	2283	1	-	1	2	1	-	
7204		2	2283	1	-	1	2	1	-	
7214		7a	2283	2	-	2	4	2	-	
7244		5	713	1	2	2	3	3	3	
7247 (7291)		5	674	1	2	2	3	3	3	
7248 (7291)		5	674	1	2	2	3	3	3	
7249		4b	1251	2	3	4	5	6	7	
7251		4a	2264	1	-	1	2	1	-	

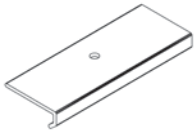

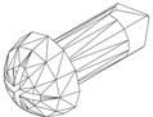
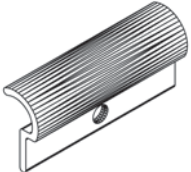

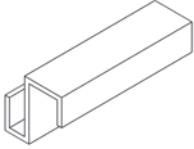

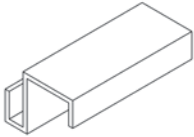
Stykliste

Pakke 3					Antal stk. / Model					
Kode nr.	Artikel	Montage- trin	Længde i mm	Antal i delpakke	8100	10000	11900	13800	15700	Profil
7255		4b	1356	4	4	6	8	10	12	
7258		4a	2264	2	-	2	4	2	-	
7291 (7247 & 7248)		5	674	2	4	4	6	6	6	
7293		5	713	1	2	2	3	3	3	
7294		4b	708	1	2	2	3	3	3	
7296		7a	707	6	8	10	12	14	16	
7297		7a	687	6	8	10	12	14	16	
7298		7a*	30	6	8*	10*	12*	14*	16*	
7299		7a*	30	6	8*	10*	12*	14*	16*	

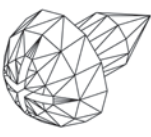
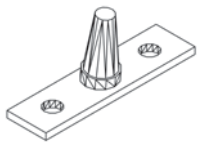

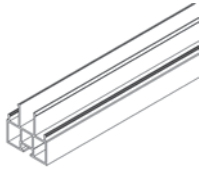
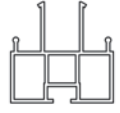

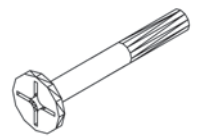
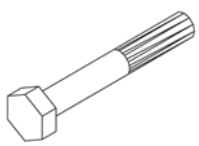
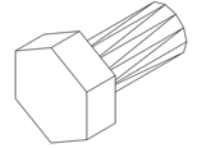

ZEUS 2

Stykliste



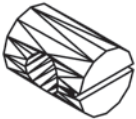
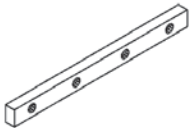

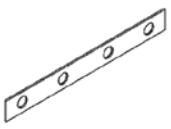
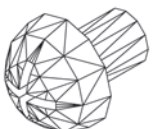





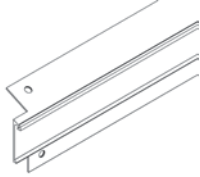

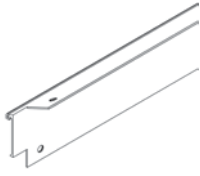

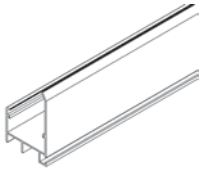
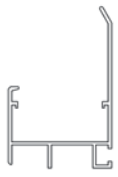
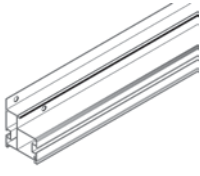
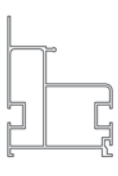
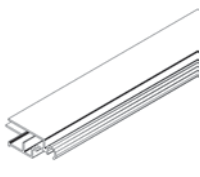
Pakke 3					Antal stk. / Model					
Kode nr.	Artikel	Montage- trin	Længde i mm	Antal i delpakke	8100	10000	11900	13800	15700	Profil
7343		7a	56	4	4	6	8	10	12	
7349		7a 8	3.9x10	24	38	46	56	64	72	
7369		8	30	2	4	4	6	6	6	
7406		7b	30	6	14	16	18	20	22	
7407		7b	30	6	14	16	18	20	22	

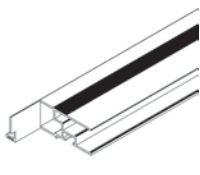
Pakke 4					Antal stk. / Model					
Kode nr.	Artikel	Montage- trin	Længde i mm	Antal i delpakke	8100	10000	11900	13800	15700	Profil
1006		4b 5 6a 6b 9	3.5x6	6	32	32	38	38	38	
6056		4b	46	2	4	4	6	6	6	
6090		7b 7c	28000	1	77000	85500	94000	103000	112000	
7005		3	1775	6	6	8	10	12	14	
7032		7b	1793	6	6	8	10	12	14	
7034		7b 7c	733	8	16	18	20	22	24	
7047		4b	M6x48	5	2	4	4	6	8	
7050		7b	M6x42	43	126	138	150	162	174	
7052		1, 2 3, 4 5, 6 7a	M6x12	74	154	176	202	224	246	

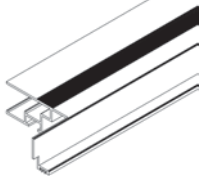
Styklister

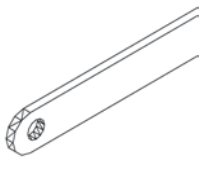

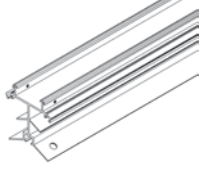







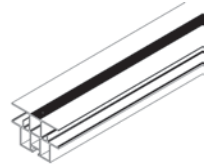
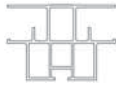
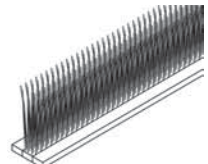

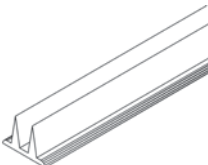

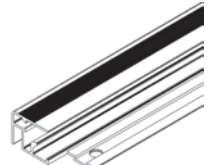
Pakke 4					Antal stk. / Model					
Kode nr.	Artikel	Montage- trin	Længde i mm	Antal i delpakke	8100	10000	11900	13800	15700	Profil
7053		1, 2 3, 4 5, 6 7, 8	M6x4	117	307	341	379	413	447	
7054		4b 6	M6x100	2	12	12	14	14	14	
7055		4b 6	M6x10 x14	2	12	12	14	14	14	
7061		1 2 4a 7a	117	3	15	15	15	15	15	
7062		4	235	3	6	7	8	9	10	
7063		3	255	6	8	10	12	14	16	
7064		1 2 4a 7a	117	3	11	11	11	11	11	
7080		1 2 4a 7a	M6x8	12	60	60	60	60	60	
7090		5	324	1	2	2	3	3	3	

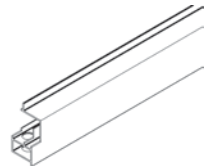
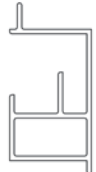





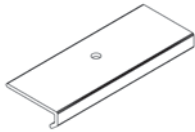

Stykliste

Pakke 4					Antal stk. / Model					
Kode nr.	Artikel	Montage- trin	Længde i mm	Antal i delpakke	8100	10000	11900	13800	15700	Profil
7205		2	3027	1	-	-	-	1	2	
7206		2	3027	1	-	-	-	1	2	
7215		7a	3027	2	-	-	-	2	4	
7224		1	3008	2	-	-	-	2	4	
7244		5	713	1	2	2	3	3	3	
7247 (7291)		5	674	1	2	2	3	3	3	
7248 (7291)		5	674	1	2	2	3	3	3	
7249		4b	1251	3	3	4	5	6	7	
7252		4a	3008	1	-	-	-	1	2	

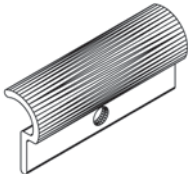

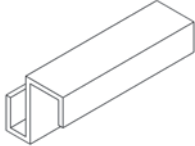

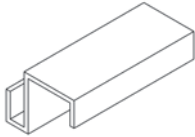



ZEUS 2

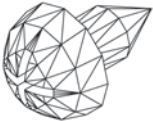
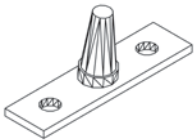
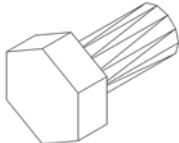



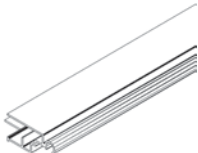

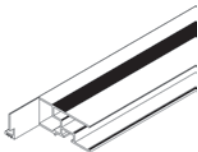

Stykliste

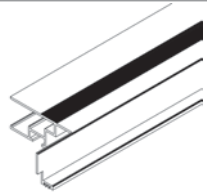
Pakke 4					Antal stk. / Model					
Kode nr.	Artikel	Montage- trin	Længde i mm	Antal i delpakke	8100	10000	11900	13800	15700	Profil
7255		4b	1356	6	4	6	8	10	12	
7259		4a	3008	2	-	-	-	2	4	
7291 (7247 & 7248)		5	674	2	4	4	6	6	6	
7293		5	713	1	2	2	3	3	3	
7294		4b	708	1	2	2	3	3	3	
7296		7a	707	8	8	10	12	14	16	
7297		7a	687	8	8	10	12	14	16	
7298		7a*	30	8	8*	10*	12*	14*	16*	
7299		7a*	30	8	8*	10*	12*	14*	16*	

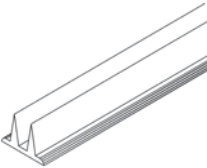
Pakke 4					Antal stk. / Model					
Kode nr.	Artikel	Montage- trin	Længde i mm	Antal i delpakke	8100	10000	11900	13800	15700	Profil
7343		7a	56	6	4	6	8	10	12	
7349		7a 8	3.9x10	32	38	46	56	64	72	
7369		8	30	2	4	4	6	6	6	
7406		7b	30	8	14	16	18	20	22	
7407		7b	30	8	14	16	18	20	22	

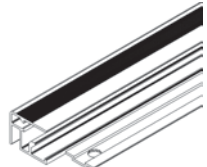
Styklister

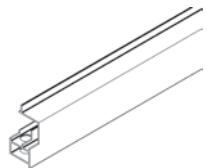
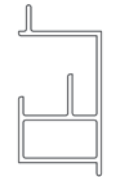
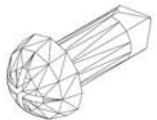
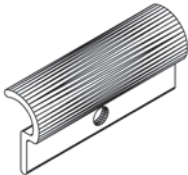
Pakke 5 Ventilationsvindue					Antal stk. / Model					
Kode nr.	Artikel	Montage- trin	Længde i mm	Antal i delpakke	8100	10000	11900	13800	15700	Profil
1006		4b 5 6a 6b 9	3.5x6	6	32	32	38	38	38	
6056		4b	46	2	4	4	6	6	6	
7052		1, 2 3, 4 5, 6 7a	M6x12	4	154	176	202	224	246	
7053		1, 2 3, 4 5, 6 7, 8	M6x4	4	307	341	379	413	447	
7054		4b 6	M6x100	2	12	12	14	14	14	
7055		4b 6	M6x10 x14	2	12	12	14	14	14	
7090		5	324	1	2	2	3	3	3	
7244		5	713	1	2	2	3	3	3	
7247 (7291)		5	674	1	2	2	3	3	3	

Pakke 5 Ventilationsvindue					Antal stk. / Model					
Kode nr.	Artikel	Montage- trin	Længde i mm	Antal i delpakke	8100	10000	11900	13800	15700	Profil
7248 (7291)		5	674	1	2	2	3	3	3	
7291 (7247 & 7248)		5	674	2	4	4	6	6	6	
7293		5	713	1	2	2	3	3	3	
7294		4b	708	1	2	2	3	3	3	
7349		7a 8	3.9x10	2	38	46	56	64	72	
7369		8	30	2	4	4	6	6	6	



VIGTIGT:

Materialer eller værktøj, der skal anvendes til fremstilling af fundamentet / soklen indgår ikke i leverancen.



Oplysninger vedr. fundamentet er at betragte som vejledende forslag.

Drivhuset skal opstilles på et stabilt fundament / sokkel. Soklen kan laves f.eks. som en fuldstøbt betonsokkel eller bygges op i mursten eller Leca-sten.

Soklen skal gå ned i frostfri dybde (80-90 cm) for at undgå skævvridninger.

Såfremt De er usikker på soklens konstruktion, anbefaler vi Dem at kontakte en fagmand.

Sokkelmålene fremgår af tabellen på side 37. Vær opmærksom på, at der til senere fastgørelse af bundramme skal være 50 mm plads enten på yder- eller på indersiden af bundrammen, se illustrationen på side 37.



VIGTIGT:

Soklen skal være meget nøjagtigt i vater og de fire hjørner skal være retvinklede. Anvend et langt vaterpas og en stor vinkel til dette.

Tip: Sørg for, at de to X-mål som vist på tegningen side 37 er helt ens. Dermed er De sikker på, at de fire hjørner er retvinklede.

Byg derefter drivhuset ovenpå det færdige fundament.

Bundrammen skal først fastgøres til fundamentet, når hele drivhuset er færdigmonteret, og alt er i vater, lod og vinkel.

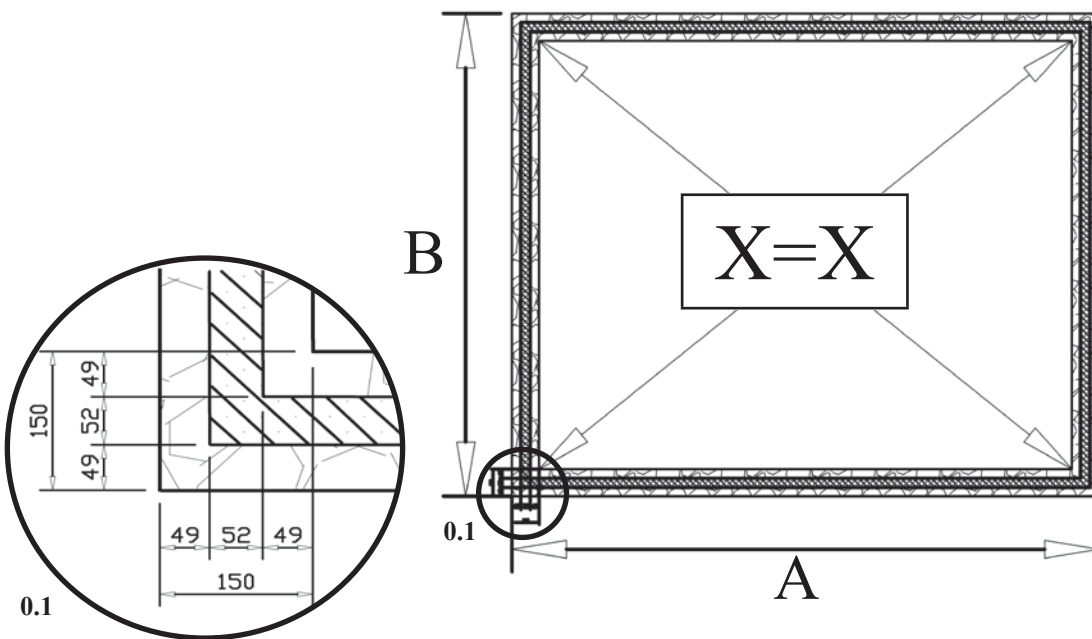
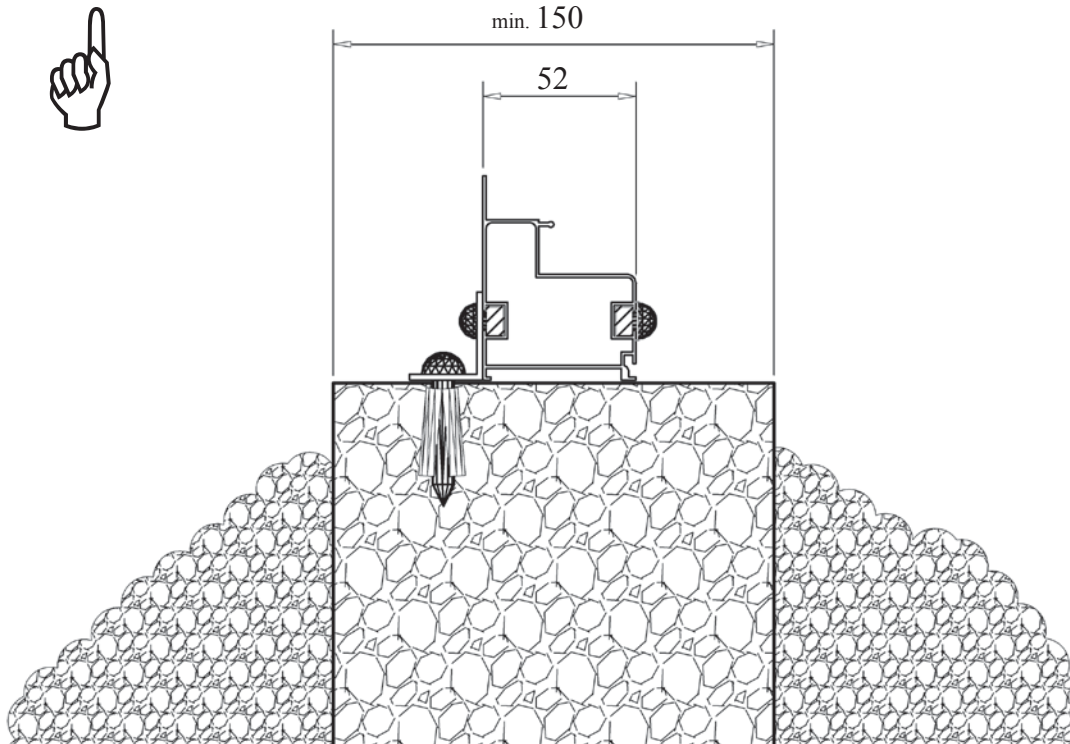

	8100	10000	11900	13800	15700
A	3242 mm	3986 mm	4730 mm	5474 mm	6218 mm
B	2662 mm	2662 mm	2662 mm	2662 mm	2662 mm

Fundament / sokkel

1

Model				
8100	10000	11900	13800	15700
7001				
4	2	0	0	0
7002				
0	2	4	2	0
7003				
2	2	2	2	2
7004				
2	2	2	2	2
7052				
8	8	8	8	8
7053				
8	8	8	8	8
7061				
8	8	8	8	8
7064				
4	4	4	4	4
7080				
32	32	32	32	32
7095				
4	4	4	4	4
7200				
4	4	4	4	4
7224				
0	0	0	2	4
7236				
4	4	4	4	4

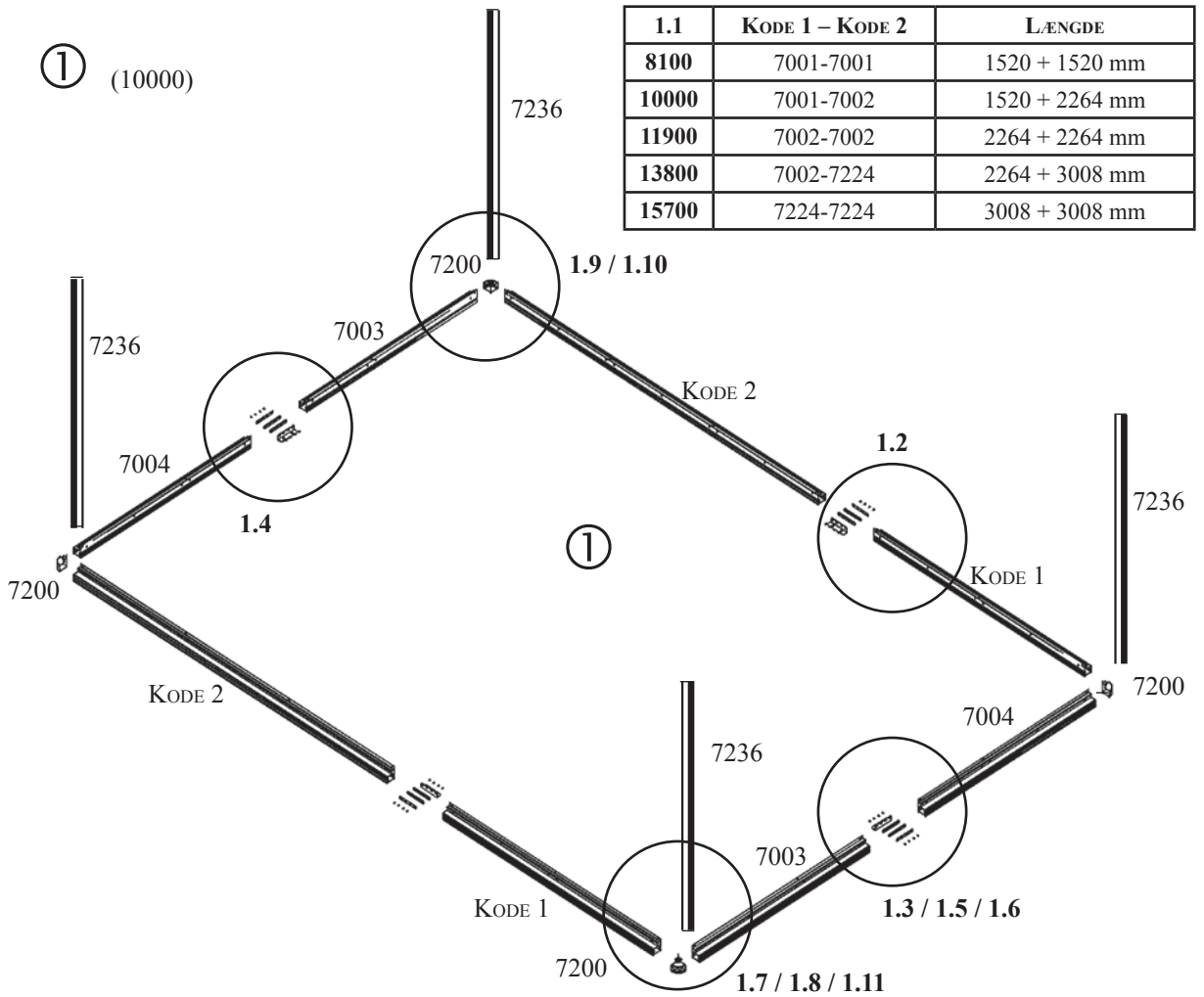

1.1	KODE 1 – KODE 2	LÆNGDE
8100	7001-7001	1520 + 1520 mm
10000	7001-7002	1520 + 2264 mm
11900	7002-7002	2264 + 2264 mm
13800	7002-7224	2264 + 3008 mm
15700	7224-7224	3008 + 3008 mm

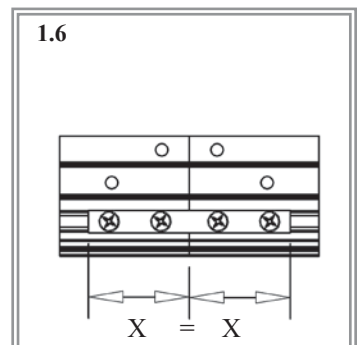
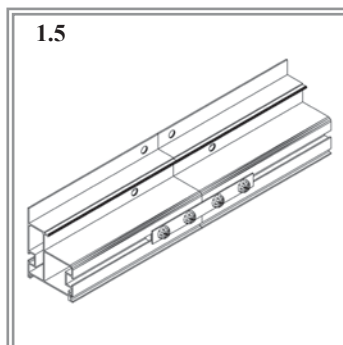
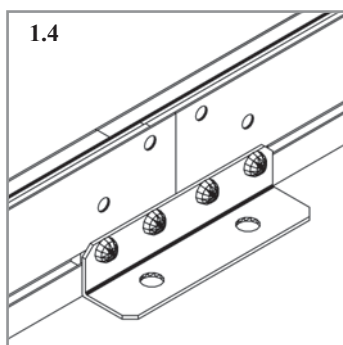
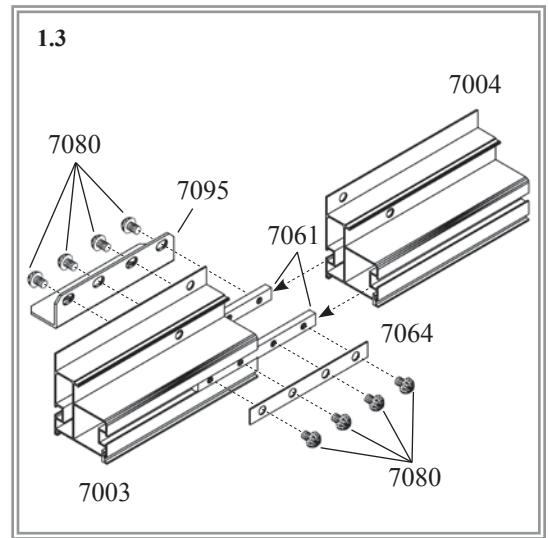
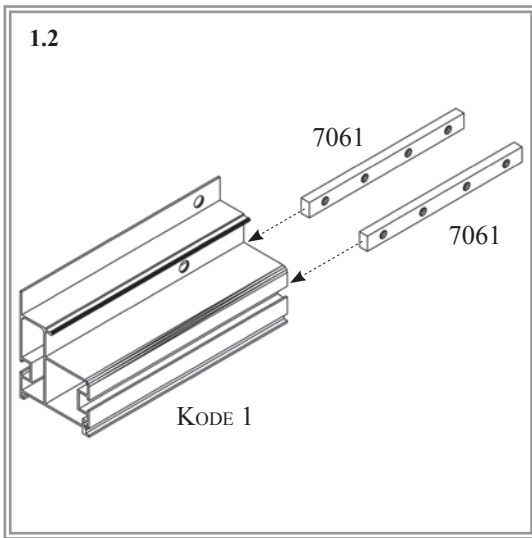

BUNDRAMME / HJØRNESTOLPER

BEMÆRK VENLIGST:

Bundrammen skal først skrues fast på fundamentet ved hjælp af vinkel (7095), når alle øvrige dele i drivhuskonstruktionen er monteret.

Der bør være minimum to personer til at samle og montere dette drivhus.



Tegninger med enkeltramme (f.eks. 1.9) er set indefra.

Tegninger med dobbeltramme (f.eks. 1.7) er set udefra.

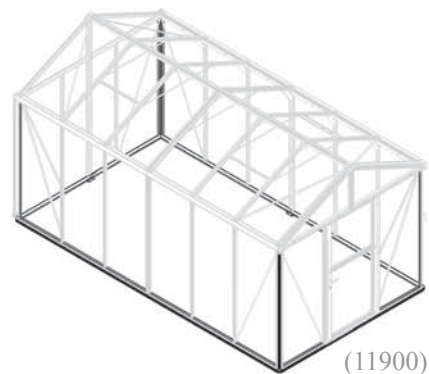

Tag bundrammeprofilerne 7003 og 7004 ud af henholdsvis delpakke 1-2, og læg profilerne på jorden som vist på den store ill. ① på side 38. Dernæst de 4 modelspecifikke bundrammeprofiler 7001, 7002 eller 7224 fra delpakke 2, 3 eller se tabel (1.1) og saml disse to og to ved hjælp af samlestykke 7061 (1.2). Ved hjælp af bolt 7080 (1.3) spændes samlestykke 7061 og laske 7064 henholdsvis 7095 løst sammen. Samlestykkerne skal placeres i midten (1.6). Derefter fastspændes bolte 7080. Forbind bundprofil 7003 med 7004 på samme måde.

Efterfølgende forbindes de fire bundprofiler ved hjælp af de afrundede plastichjørnesamlebeslag 7200 (1.7/1.8) og med hjørnestolperne 7236 (1.9/1.10).

Hver hjørnestolpe fastgøres for neden med 2 bolte 7052 og to møtrikker 7053 (1.9. – 1.11).

Først spændes møtrikkerne løst på, derefter føres hjørnestolperne ned over bolthovederne.

Sørg for, at bolthovederne vender således, at de ubesværet kan glide ind i sporet på hjørnestolperne. Spænd derefter møtrik 7053.

Når alle fire hjørner er samlet, kontrolleres det, at profilerne danner en ret vinkel.

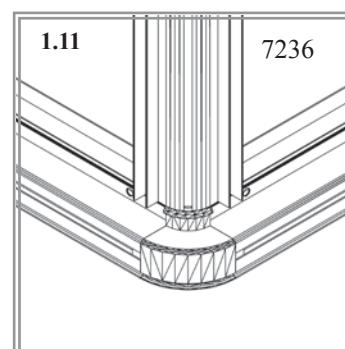
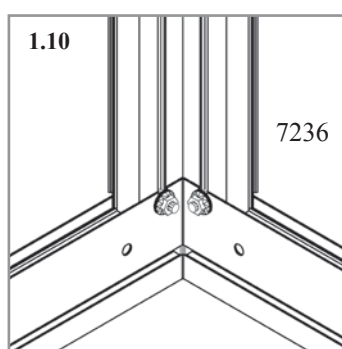
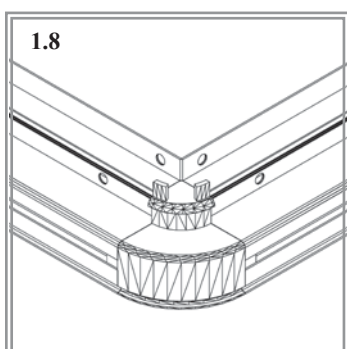
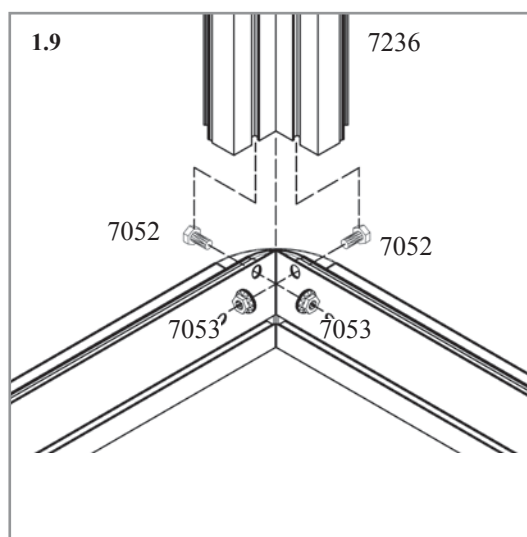
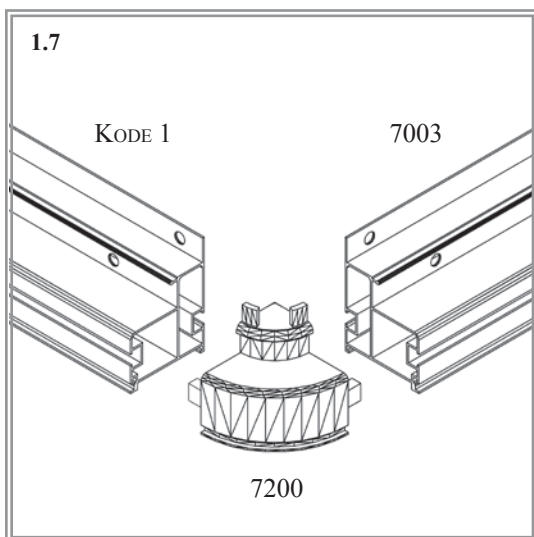

Model				
8100	10000	11900	13800	15700
7006				
3	3	3	3	3
7010				
2	2	2	2	2
7011				
2	2	2	2	2
7014				
1	1	1	1	1
7045				
1	1	1	1	1
7052				
32	32	32	32	32
7053				
32	32	32	32	32
7061				
4	4	4	4	4
7064				
4	4	4	4	4
7080				
16	16	16	16	16
7201				
2	1	0	0	0
7202				
2	1	0	0	0
7203				
0	1	2	1	0
7204				
0	1	2	1	0
7205				
0	0	0	1	2
7206				
0	0	0	1	2

② (10000)

2.1	TAGREM 1 - 2 - 3 - 4	LÆNGDE (TAGREM 1/2) + (TAGREM 3/4)
8100	7201-7202-7201-7202	1539 + 1539 mm
10000	7201-7202-7203-7204	1539 + 2283 mm
11900	7203-7204-7203-7204	2283 + 2283 mm
13800	7203-7204-7205-7206	2283 + 3027 mm
15700	7205-7206-7205-7206	3027 + 3027 mm

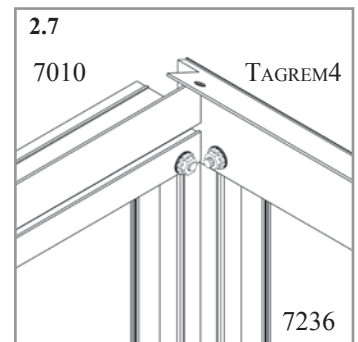
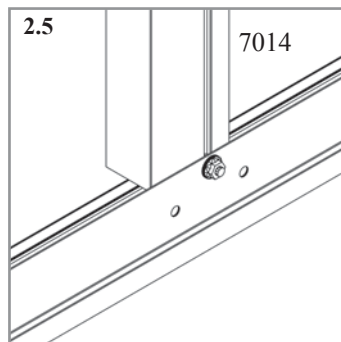
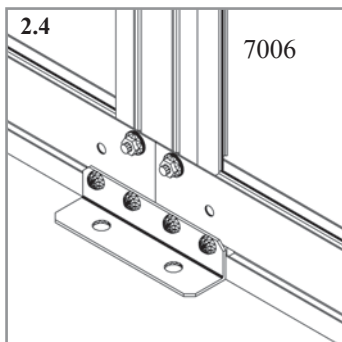
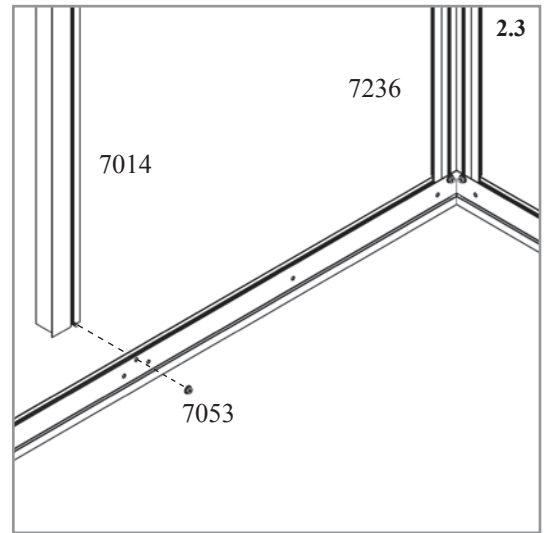
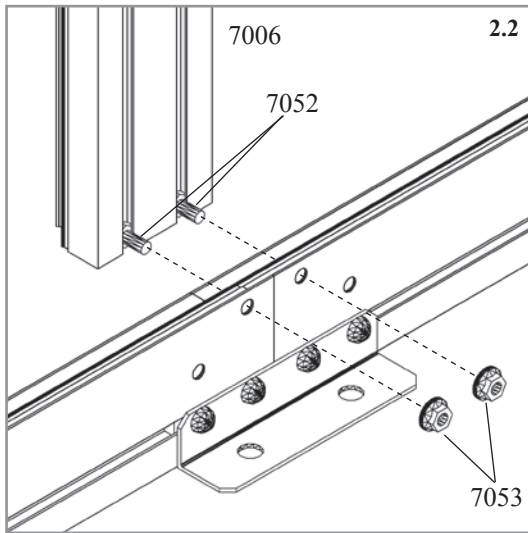
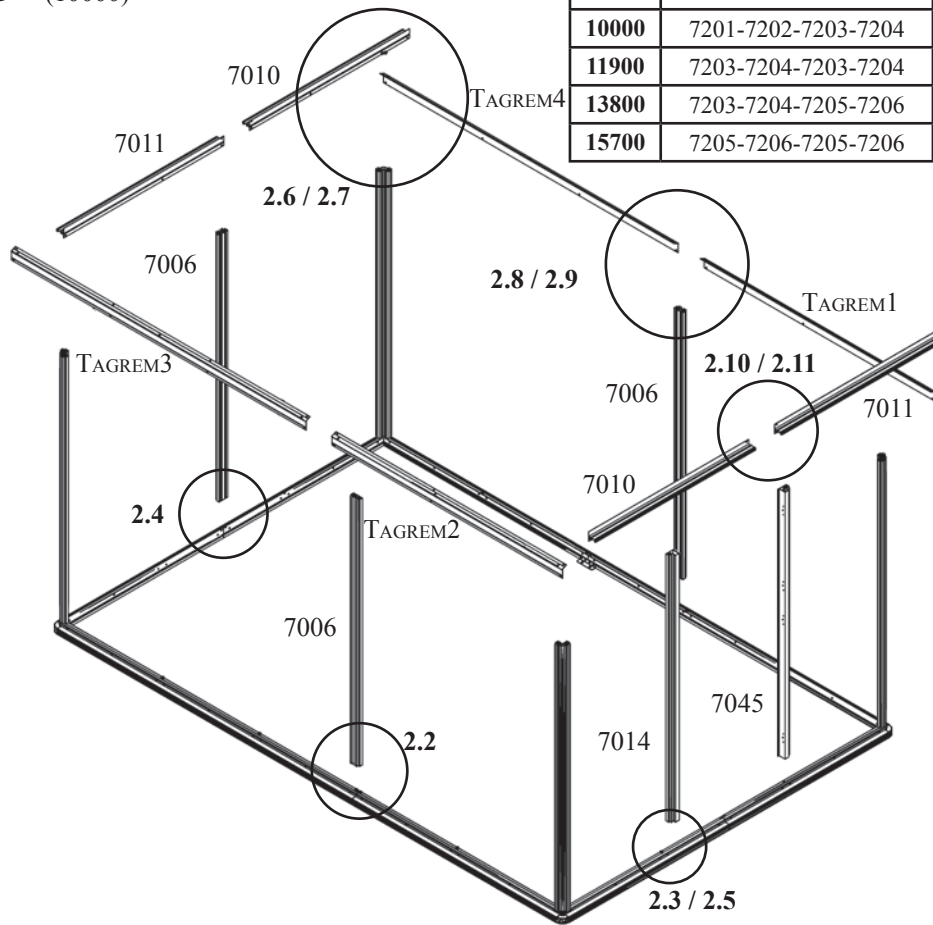

ZEUS 2

MIDTERPROFIL I LANGSIDE / TAGREM I GAVLE

BEMÆRK VENLIGST:

Til dette trin i opbygningsprocessen bør der være 2 eller 3 personer.

Møtrikker skal kun spændes let. Møtrikkerne skal senere afmonteres for at muliggøre montering af yderligere profiler.

Detaljetegningerne er set indefra.

„Tombolt“ (ekstra-bolt) = Bolt og møtrik uden synlig funktion i starten; skal anvendes til senere fastgørelse af dele.

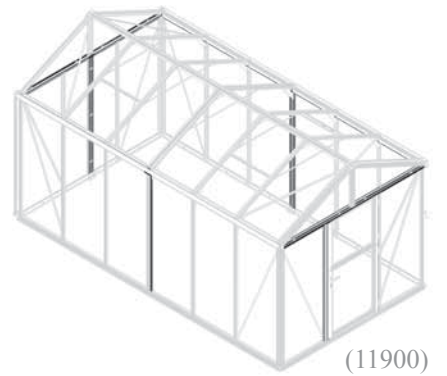

Indsæt to tombolte 7052 i hvert boltspor på 2 midterprofiler 7006 og fastgør tomboltene med hver sin møtrik 7053. Tomboltene skal senere anvendes til at fastgøre samlebeslag 7063 (2.9). Ved hjælp af bolt 7052 og møtrik 7053 fastgøres de klargjorte profiler 7006 til bundrammen, se illustration 2.2.





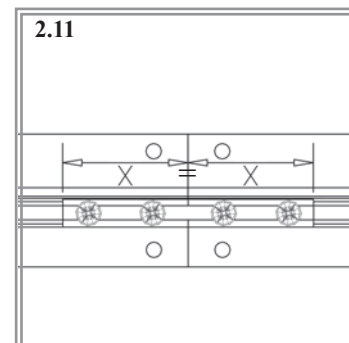
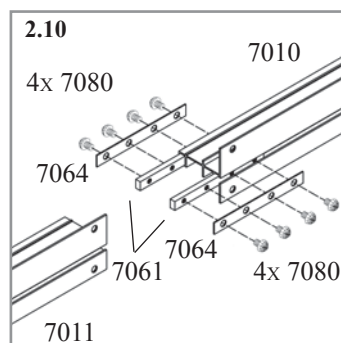
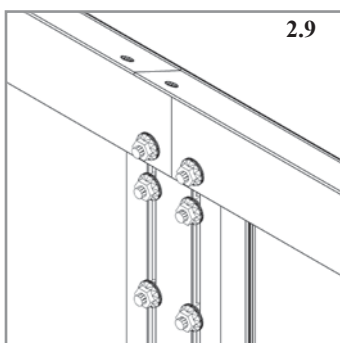
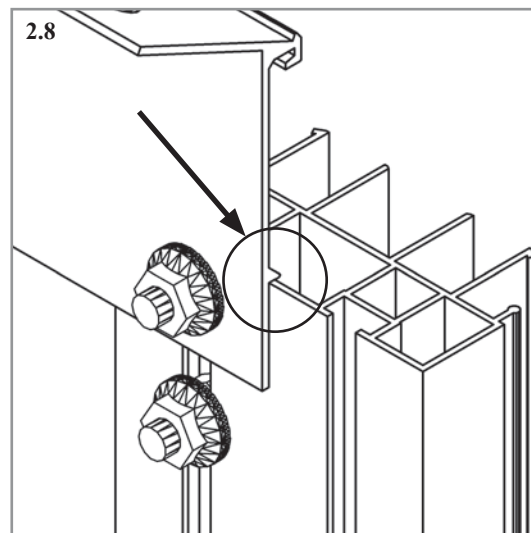
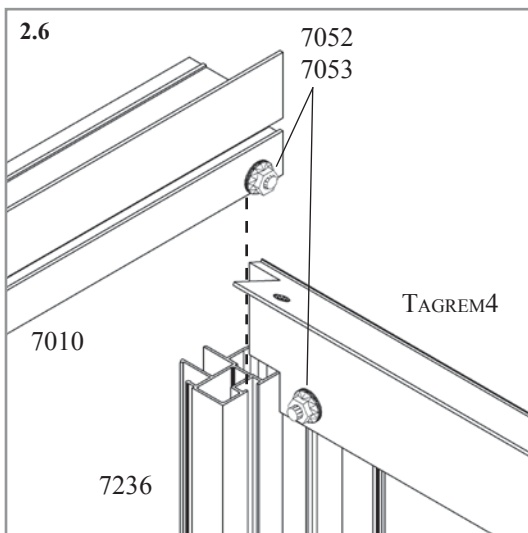

Der skal ikke en tombolt i mellemprofil 7006 på baggavlen.

Fastgør langsides mellemprofil 7006 og hjørnestolpe 7007 til tagremmen tabel (2.1), ill. (2.6-2.9). Bemærk montageflangen (2.8). Vær omhyggelig med at sikre, at tagremmene skubbes ind i hjørnet af 7236 (2.6) og sikr at flangen sidder rigtigt (2.8).

De vandrette overliggere i gavlene 7010 og 7011 samles udvendigt og indvendigt ved hjælp af profilforbinder 7061, laskeplade 7064 og bolt 7080 (2.10). Kontroller, at profilforbinderne og laskepladerne sidder i midten som vist på (2.11). Spænd derefter alle bolte.

Til sidst monteres de klargjorte profiler 7010 / 7011 til henholdsvis hjørnestolpe 7236 i for- og baggavl ved hjælp af bolt 7052 og møtrik 7053 (2.6 / 2.7). Forbind mellemprofiler 7006 i baggavlen og 7014 og 7045 i dørgavlen til bundprofilen og overliggerne 7010 / 7011 ved at skubbe bolt 7052 ind i boltsporet og fastspænde møtrik 7053 (2.2 – 2.5).



Model				
8100	10000	11900	13800	15700
7005				
6	8	10	12	14
7052				
28	36	44	52	60
7053				
28	36	44	52	60
7063				
8	10	12	14	16
7069				
4	4	4	4	4
7219				
2	2	2	2	2
7269				
4	4	4	4	4

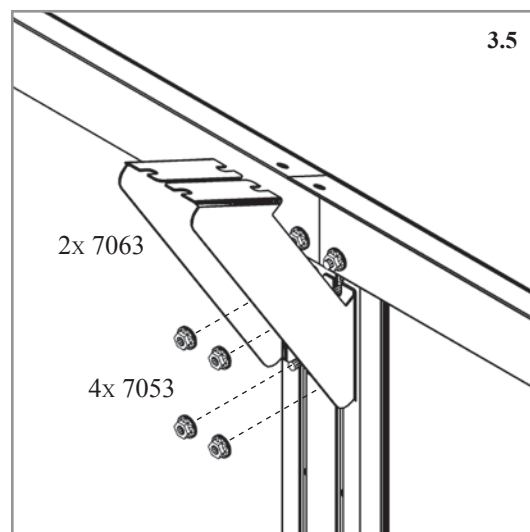
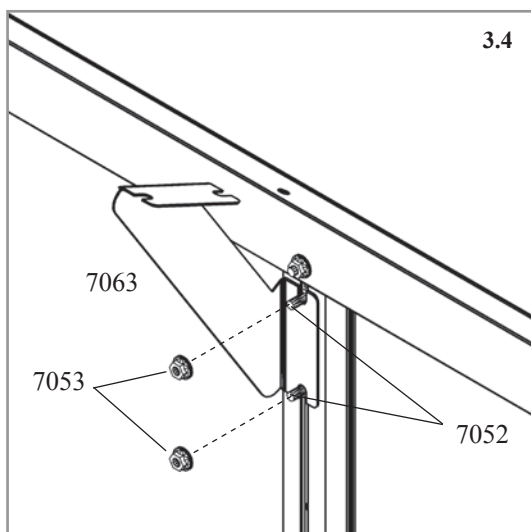
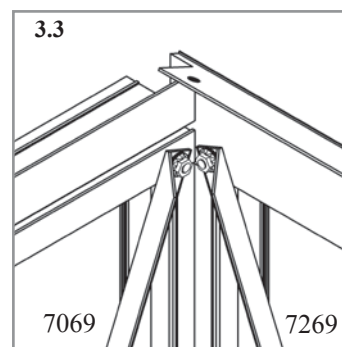
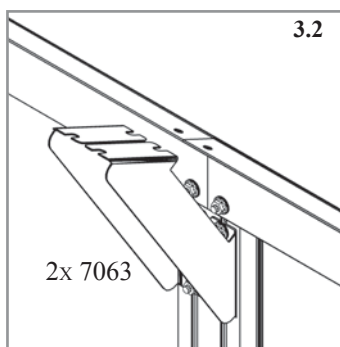
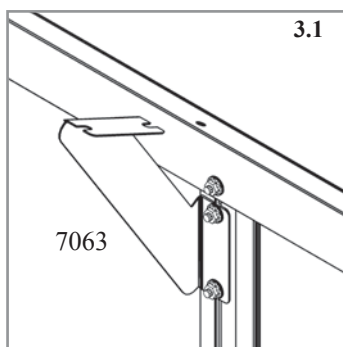
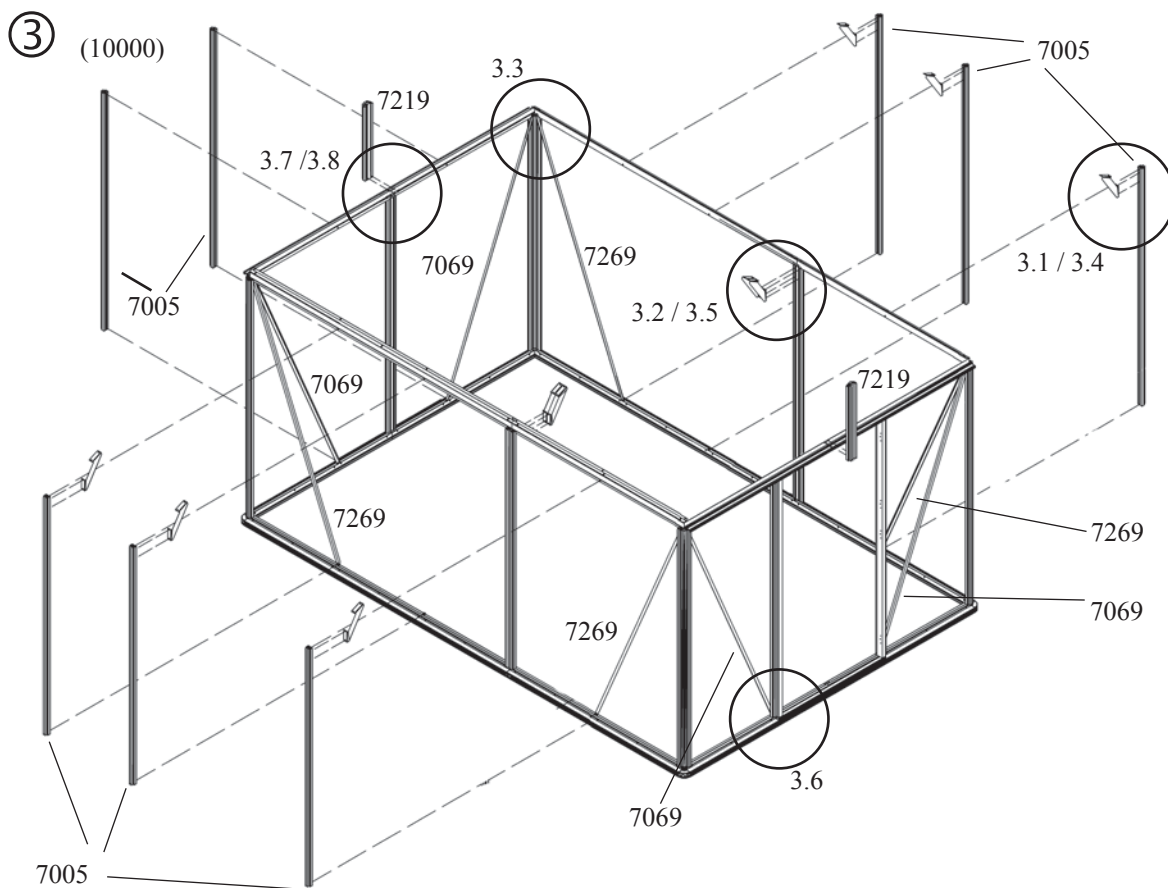

MELLEMPROFILER

BEMÆRK VENLIGST:

I denne opbygningsfase monteres vindsikringsprofilerne (de diagonale skråstivere) 7069 og 7269. Nogle af de allerede monterede bolte og møtrikker skal løsnes igen. Det kan forekomme, at skråstiverne synes at være for lange eller for korte. Ved at bevæge stellet (de samlede profiler) let frem og tilbage rettes huset ud, så skråstivernes længde passer.

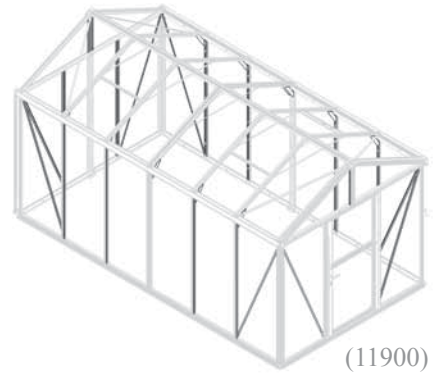

I sporet på henholdsvis 4 / 6 / 8 / 10 / 12 (afhængigt af model 8100 / 10000 / 11900 / 13800 / 15700) mellemprofiler 7005 anbringes to tombolte 7052. Fastgør boltene løst med en møtrik 7053 hver.

Som vist på den store ill. ③ fastgøres de forberedte profiler 7005 til sidevæggene. Fastgør samlebeslag 7063 til de forberedte profiler 7005 og 7006 ved sidevæggene (3.1, 3.2, 3.4, 3.5). Samlebeslagenes 7063 nøjagtige placering (højden) afgøres først senere. I baggavlen monteres to mellemprofiler 7005 uden tombolte som vist på ill ③.

Fastgør skråstiverne 7069 og 7269 (3.3/3.6). Det kan forekomme, at skråstiverne synes at være for lange eller for korte. Ved at bevæge stellet (de samlede profiler) let frem og tilbage (diagonalt) rettes huset ud, så skråstivernes længde passer.

Tagrygstøtterne 7019 (3.7 / 3.8) monteres, og der anbringes en tombolt 7052 med møtrik 7053 i hvert af de to profilspor i 7219, se (3.7) og (4a.3).

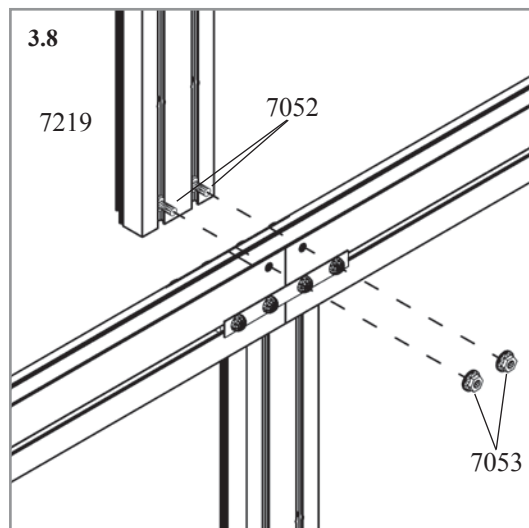
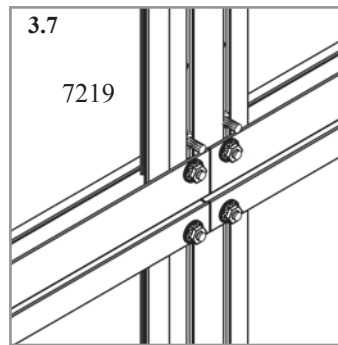
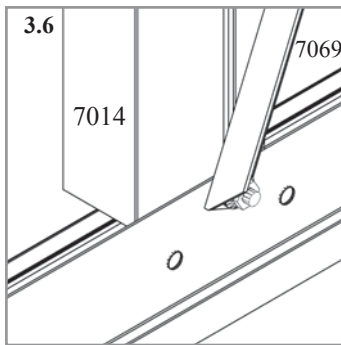

Mellemprofiler

4a

④ a (10000)

4A.1	TAGRYG 1 – TAGRYG 2	LÆNGDE
8100	7250-7250	1520 + 1520 mm
10000	7250-7251	1520 + 2264 mm
11900	7251-7251	2264 + 2264 mm
13800	7251-7252	2264 + 3008 mm
15700	7252-7252	3008 + 3008 mm

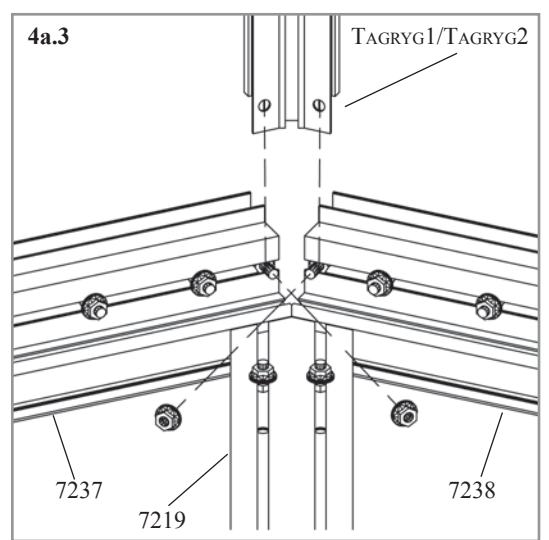
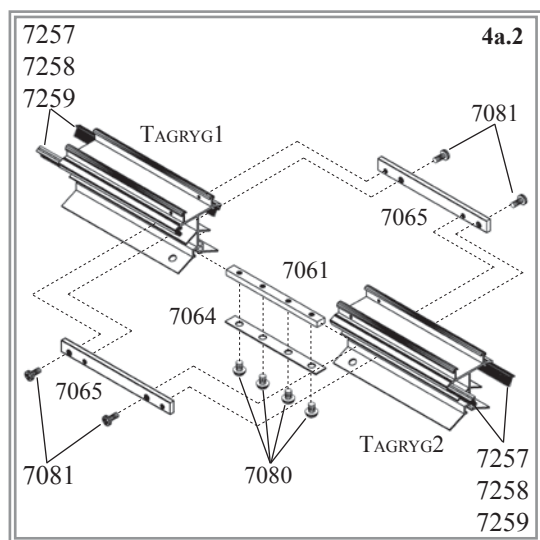
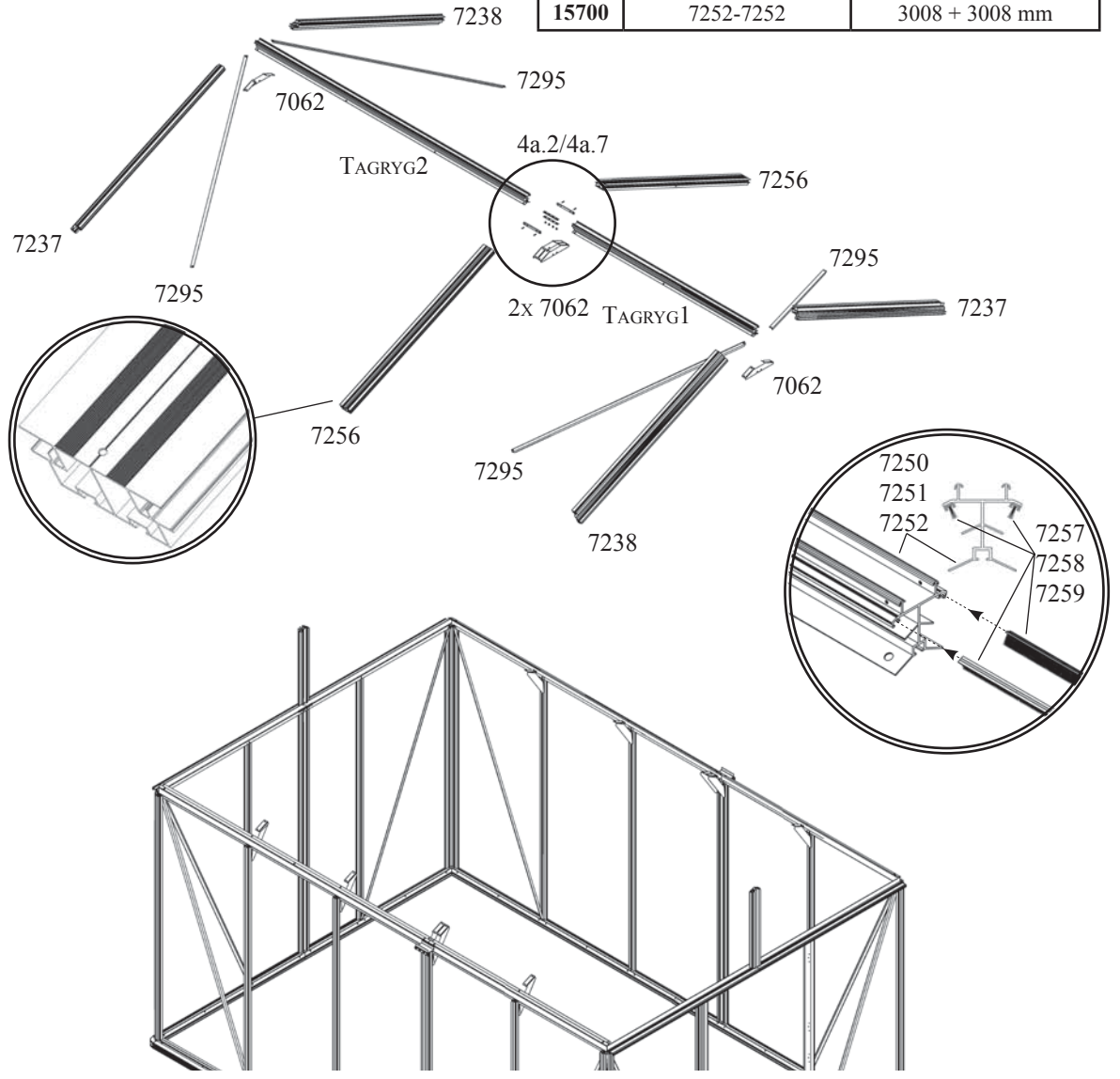

Model				
8100	10000	11900	13800	15700
7052				
40	40	40	40	40
7053				
40	40	40	40	40
7061				
1	1	1	1	1
7062				
4	4	4	4	4
7064				
1	1	1	1	1
7065				
2	2	2	2	2
7080				
4	4	4	4	4
7081				
4	4	4	4	4
7237				
2	2	2	2	2
7238				
2	2	2	2	2
7250				
2	1	0	0	0
7251				
0	1	2	1	0
7252				
0	0	0	1	2
7256				
2	2	2	2	2
7257				
4	2	0	0	0
7258				
0	2	4	2	0
7259				
0	0	0	2	4
7295				
4	4	4	4	4

ZEUS 2

TAGRYG / TAGPROFILER

BEMÆRK VENLIGST:

Til dette trin i opbygningsprocessen bør der være to eller tre personer. De får brug for en eller gerne to stiger.

Nogle møtrikker 7053 skal løsnes for at muliggøre montering af yderligere profiler.

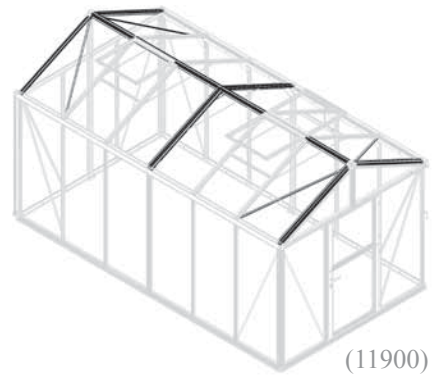

Forbered tagryggen til påsætning ved at parre tagrygsdelene som vist i tabel 4a.1. Skub plastic tætningsliste 7257, 7258 eller 7259 ind i kanalerne på begge sider af tagryggen som vist i den største cirkel.

Nu samles tagryggens to dele ved hjælp af tagrygsamlebeslagene 7061 / 7064 / 7080 og 7065 / 7081.

Læg tagryggen midlertidigt til side og anbring to tombolte 7052 i profilerne 7237 og 7238 og spænd disse let fast med møtrikker 7053 (4a.3). Disse skal senere anvendes til fastgørelse af tagafstiver/rygningsbeslag 7062.

Anbring gavlprofil 7237 og 7238 på tagrygstøtten 7219 (4a.3) og (4a.4) og spænd først profilen fast forneden ved tagremmen ved hjælp af bolt 7052 og møtrik 7053. Gentaq dette trin i den modsatte gavl.

Nu forbindes den klargjorte tagryg med gavlprofilerne 7237 og 7238 (4a.5). Monter rygningsbeslag 7062 med de formonterede tombolte i 7219, 7237 og 7238 (4a.6). Derefter monteres diagonalafstiverne 7295 mellem tagryggen (4a.6) og tagremmen (4a.8).

Forbered tagmellemprofiler 7256 ved at fastgøre 4 tombolte 7052 med møtrik 7053 i hver og monter dem mellem tagryggen og tagremmen (se den store ill. 4a). Vær opmærksom på, at det lille hul på den udvendige side af 7256 vender mod tagremmen.

Til sidst monteres de dobbelte rygningsbeslag 7062 ved tagryggen (4a.7) og samlebeslag 7063 ved tagremmen (4a.8).

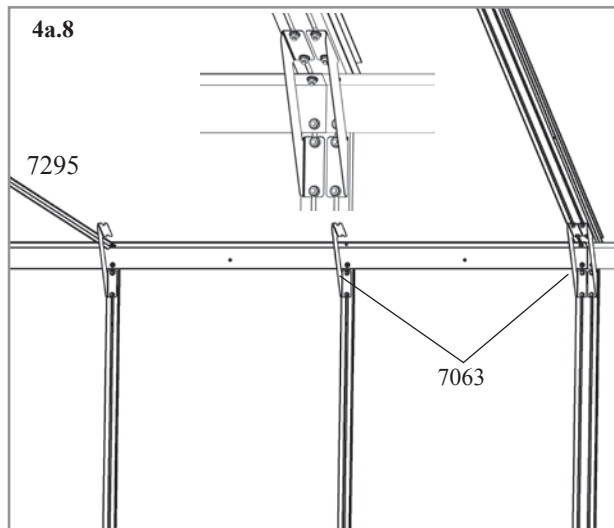
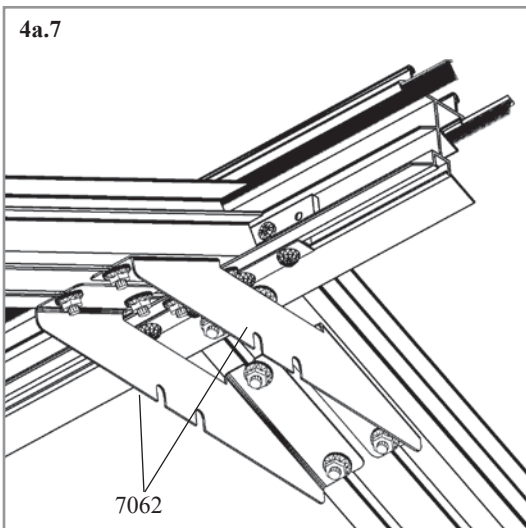
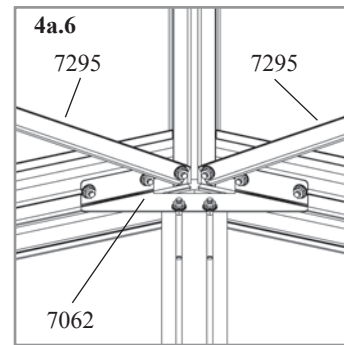
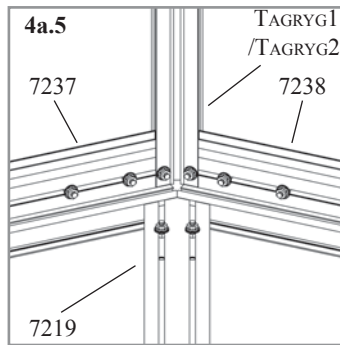
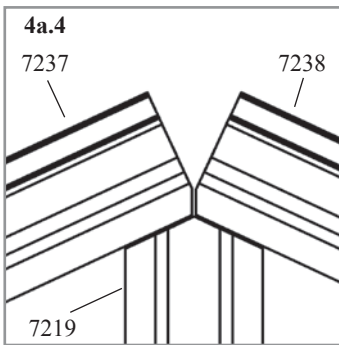

4b

④b (10000)

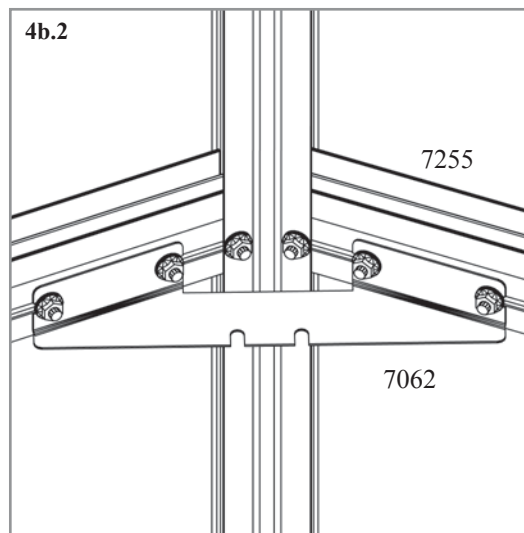
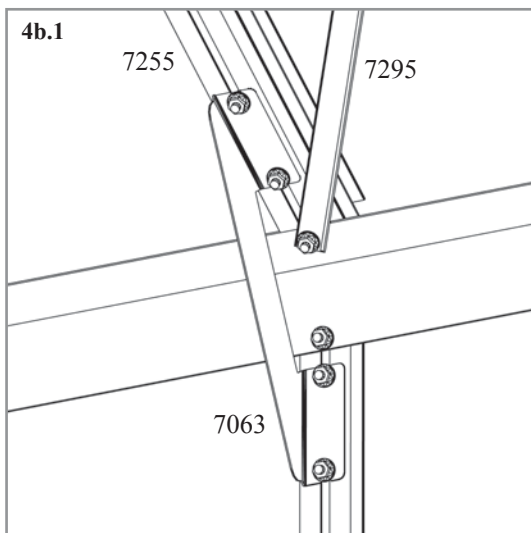
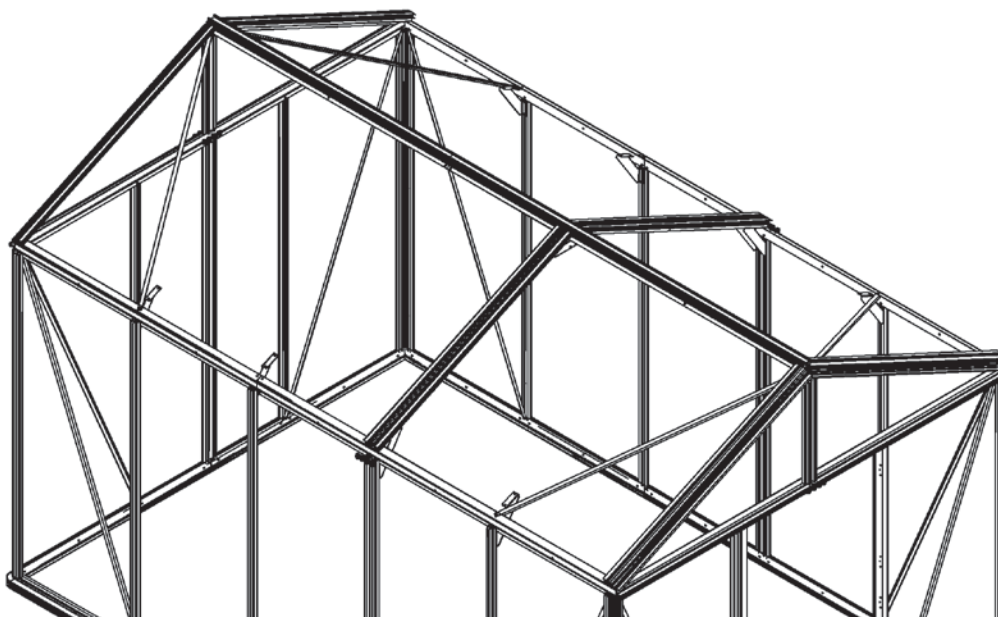
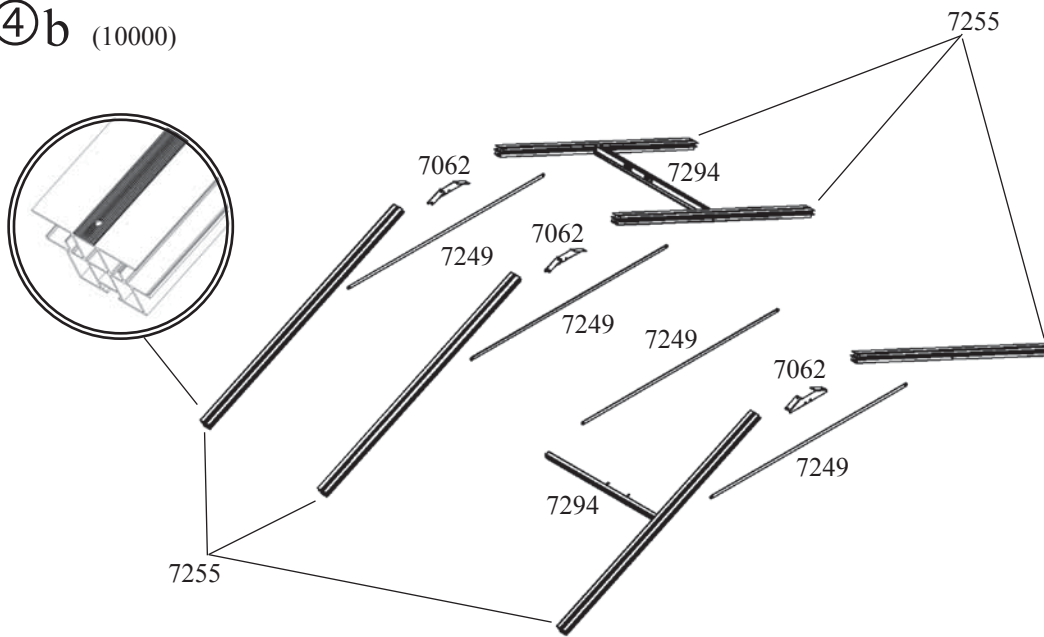

Model				
8100	10000	11900	13800	15700
1006				
8	8	12	12	12
6056				
4	4	6	6	6
7047				
2	4	4	6	8
7048				
0	1	2	2	2
7052				
24	36	48	60	72
7053				
24	36	48	60	72
7054				
4	4	6	6	6
7055				
4	4	6	6	6
7062				
2	3	4	5	6
7249				
3	4	5	6	7
7255				
4	6	8	10	12
7294				
2	2	3	3	3

TAGMELLEMPROFILER

BEMÆRK VENLIGST:

Til dette trin i opbygningsprocessen bør der være to eller tre personer. De får brug for en eller gerne to stiger.

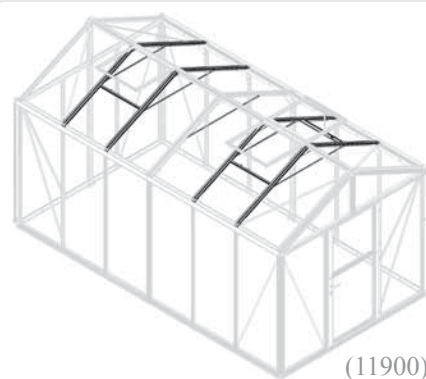

(11900)

Forbered tagmellemprofilerne 7255 ved at indføre 4 tombolte i hvert profilspor og fastgør dem løst mellem mellem tagryg (4b.1) og tagrem (4b.2) med møtrik 7053, se også ④ b. Vær opmærksom på, at det lille hul på ydersiden af 7255 er tættest på tagremmen.

Nu monteres rygningsbeslag 7062 (4b.2) og de allerede formonterede afstivere (4b.1) ved tagremmen.







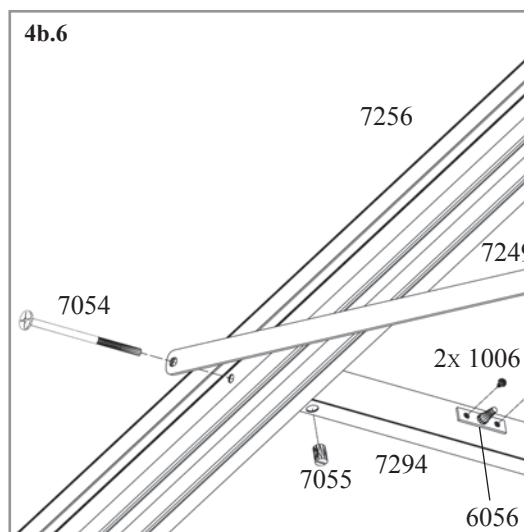
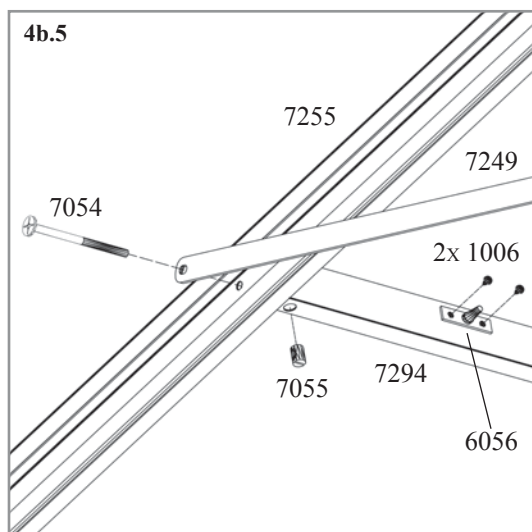
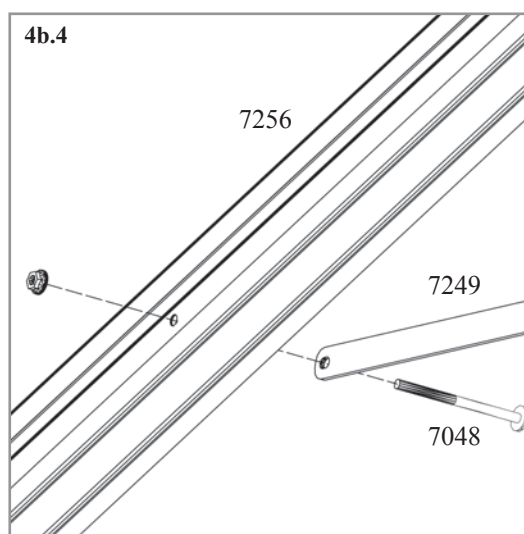
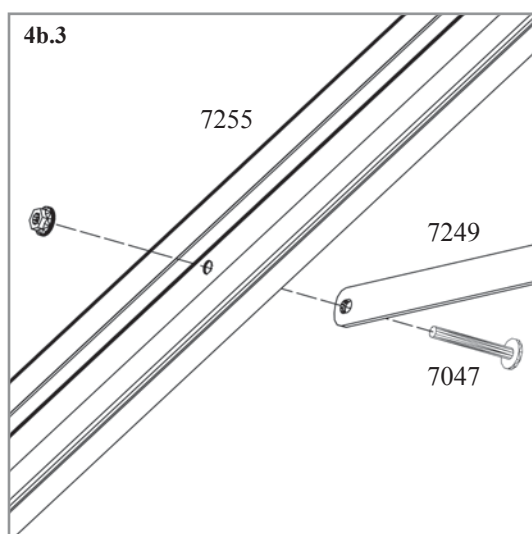

Ventilationsvinduerne kan placeres valgfrit, dog ikke i ydersektionerne eller i to nabosektioner. Vinduernes placering afgøres ved at anbringe vinduets underkarm 7294 og den vandrette tagafstiver 7249 i de sektioner, hvor vinduerne ønskes placeret.

Monter de resterende tagafstivere 7249, se (4b.3), (4b.4).

Når vinduets underkarm 7294 er monteret kan der monteres to pløkker 6056 ved hjælp af skruer 1006.

Tagmellemprofiler



Model				
8100	10000	11900	13800	15700
2x	2x	3x	3x	3x
1006				
2x2	2x2	3x2	3x2	3x2
7052				
2x4	2x4	3x4	3x4	3x4
7053				
2x4	2x4	3x4	3x4	3x4
7090				
2x1	2x1	3x1	3x1	3x1
7244				
2x1	2x1	3x1	3x1	3x1
7247 (7291)				
2x1	2x1	3x1	3x1	3x1
7248 (7291)				
2x1	2x1	3x1	3x1	3x1
7293				
2x1	2x1	3x1	3x1	3x1

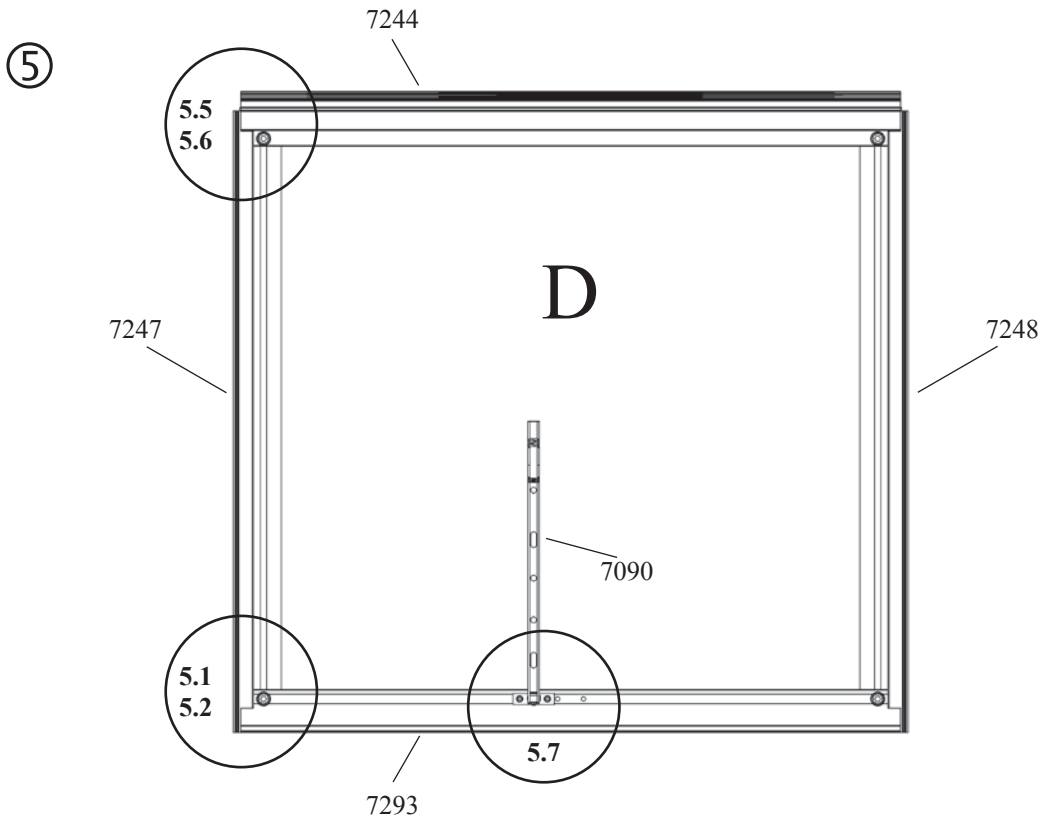

5.1	POLYCARBONAT				ANTAL / MODEL				
	10 MM		16 MM		8100	10000	11900	13800	15700
	KODE	MM	KODE	MM					
D	3695744	670 x 660	3695745	645 x 637	2x1	2x1	3x1	3x1	3x1

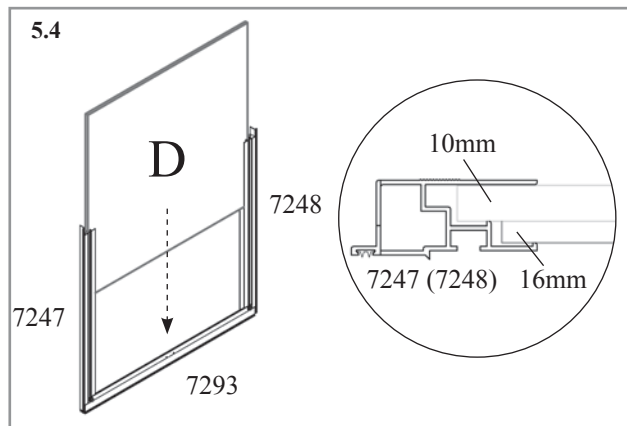
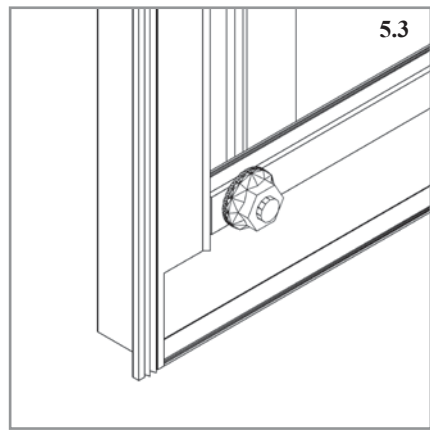
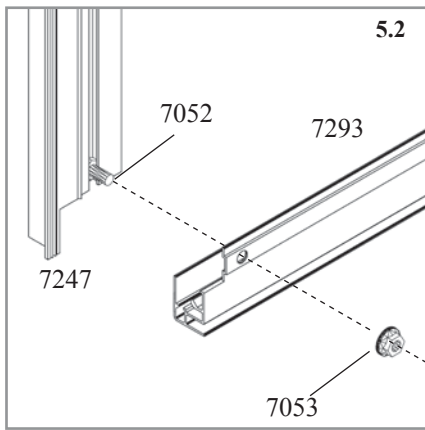

VENTILATIONSVINDUER

BEMÆRK VENLIGST:

Ved montering af ventilationsvinduet skal polycarbonatpladen isættes, inden tophængselsprofil 7244 monteres.

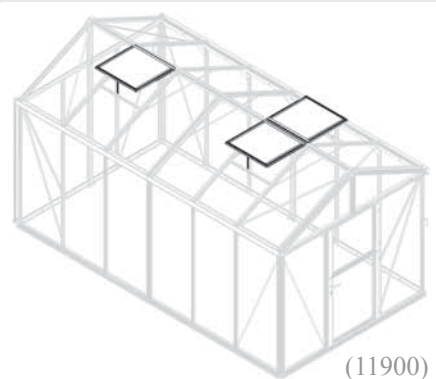

Spænd vinduets bundprofil 7293 sammen med de to sideprofiler 7247 og 7248 ved hjælp af bolt 7052 og møtrik 7053, se ⑤ (5.2), (5.3).

Før polycarbonatpladen jævnfør tabel (5.1) ind i profilerne som vist i 5.4.

Forbered vinduets topprofil 7244 ved løst i hver ende at montere bolt 7052 og møtrik 7053.

Før de løst monterede møtrikhoveder 7052 ind i sporet på profil 7247 og 7248 for derved at lukke rammen (5.5 – 5.6), samtidig med at det sikres, at polypladen sidder i sporet. Vær omhyggelig med at få vinduets hjørner i rette vinkler, inden møtrikkerne strammes – uden at overspænde.

Til sidst monteres udskyderstang 7090 på den nederste vinduesprofil 7293 (5.7) ved hjælp af skruer 1006.

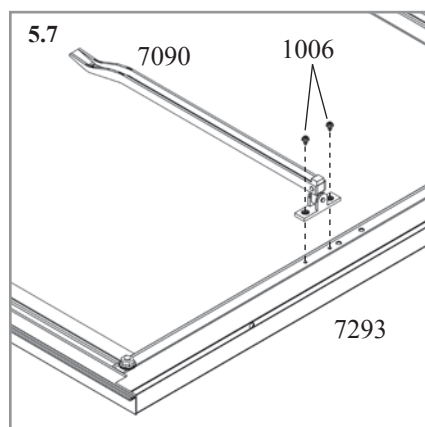
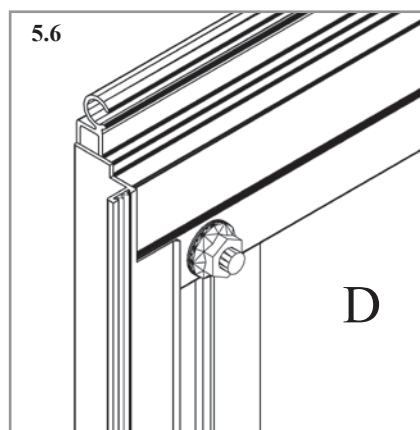
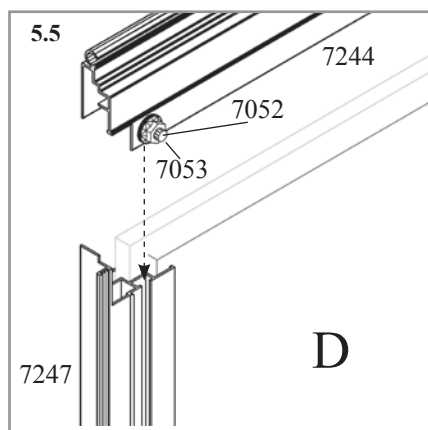

6a

⑥a

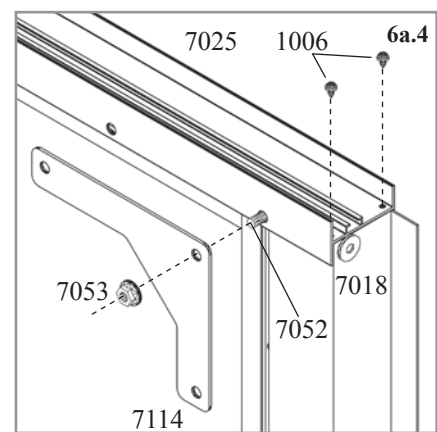
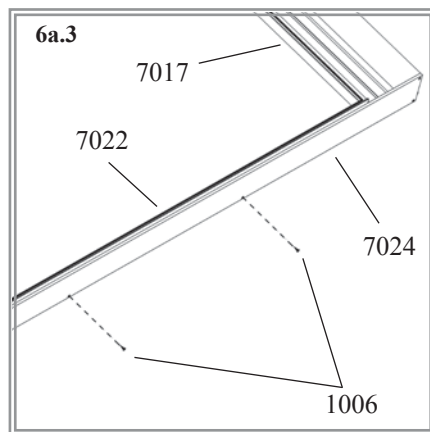
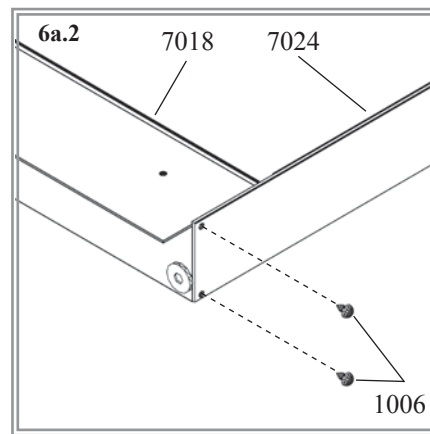
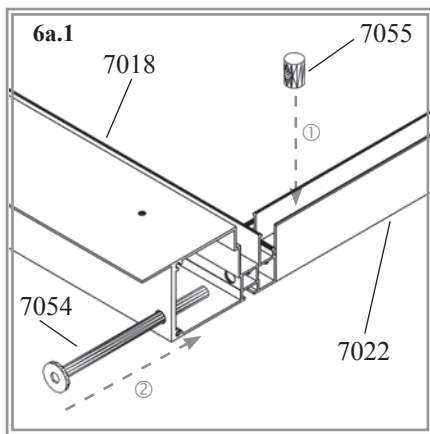
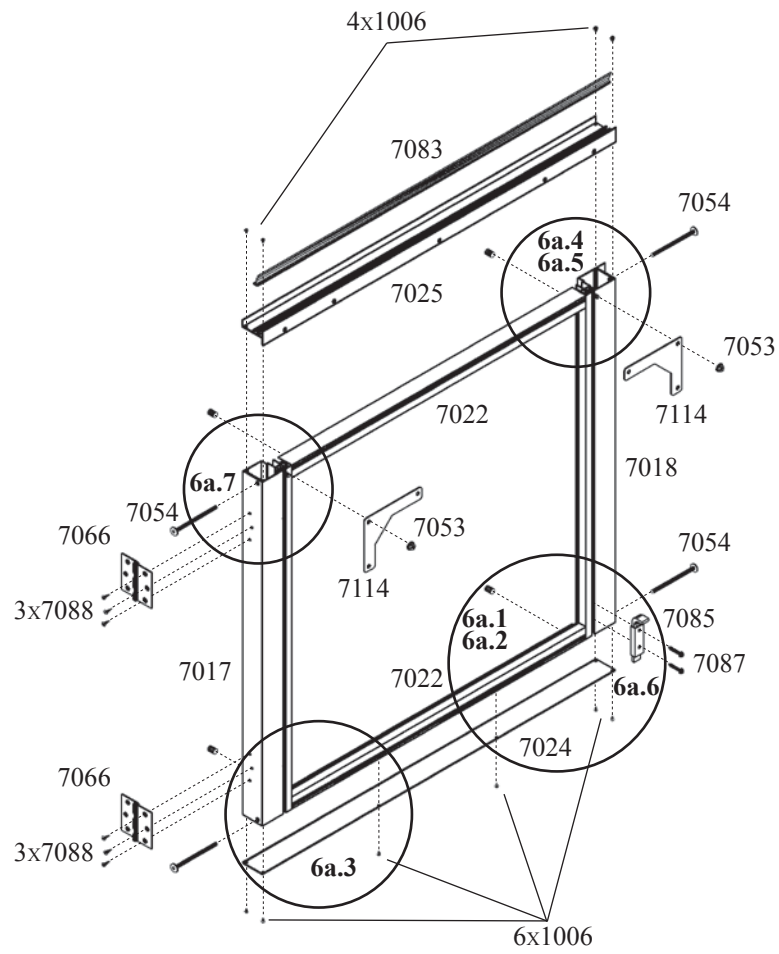

Alle modeller	
1006 x10	
7017 x1	
7018 x1	
7022 x2	
7024 x1	
7025 x1	
7052 x2	
7053 x2	
7054 x4	
7055 x4	
7066 x2	
7083 x1	
7085 x1	
7087 x2	
7088 x6	
7114 x2	

ØVERSTE DØRDEL

BEMÆRK VENLIGST:

Isætning af glas i dørene beskrives i afsnit 7c.

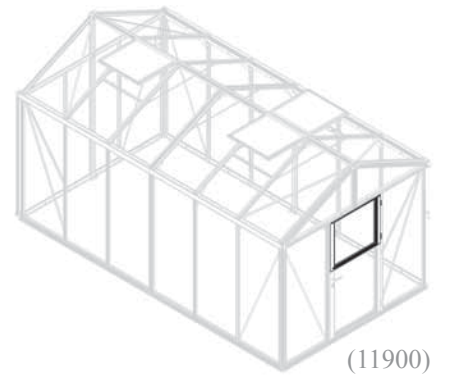

Sæt en tombolt 7052 med møtrik 7053 i profil 7017 og profil 7018.

Forbind sideprofilerne 7017 og 7018 med de vandrette profiler 7022 som vist i 6a.

Saml rammen til den øverste del af døren, der består af kode 7017, 7018 og 2 stk. 7022, ved hjælp af samleskrue 7054 og tværbøsning 7055 (6a.1) og (6a.2). Bemærk de forborede huller til montering af skudrigle 7085.

Monter afdækningsprofil 7024 fornedden (6a.3) og 7025 foroven med skruer 1006 og de tidligere monterede bolte 7052 og møtrikker 7053 (6a.4). Samtidig med montering af 7025 monteres også hjørnebeslag 7114. Tætningsliste 7083 føres ind i den øvre afdækningsprofil 7025 (6a.5). Monter skudriglen 7085 på den lodrette dørprofil 7018 (6a.6) ved hjælp af skruer 7087. Dørhængsler 7066 monteres på den lodrette dørprofil 7017 (6a.7) ved hjælp af skruer 7088.

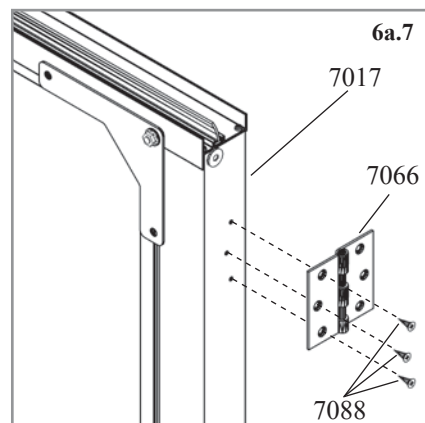
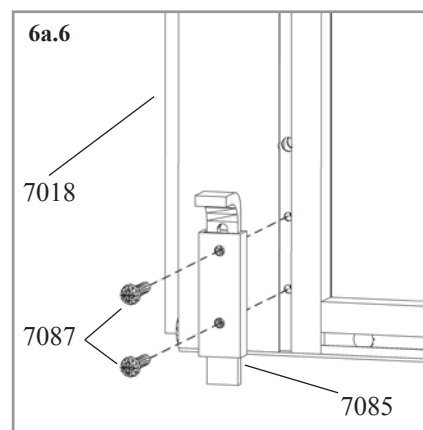
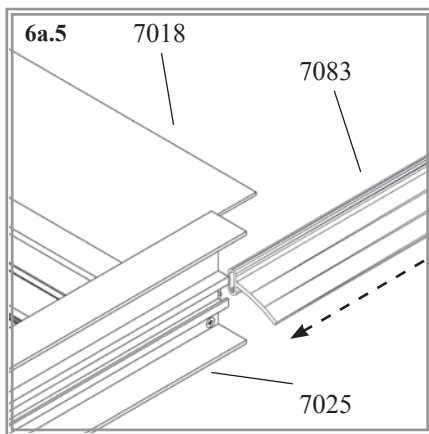

6b

6b

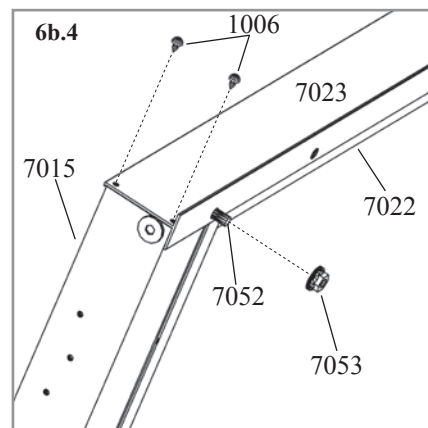
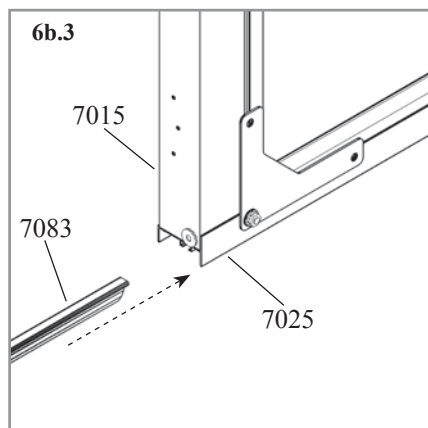
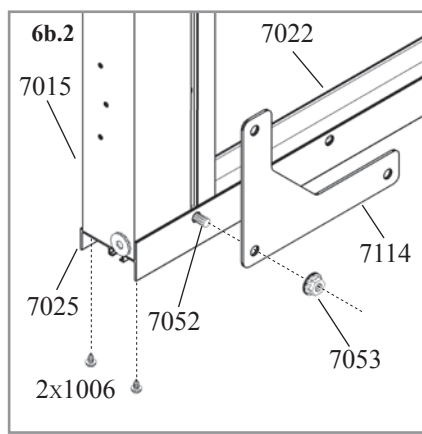
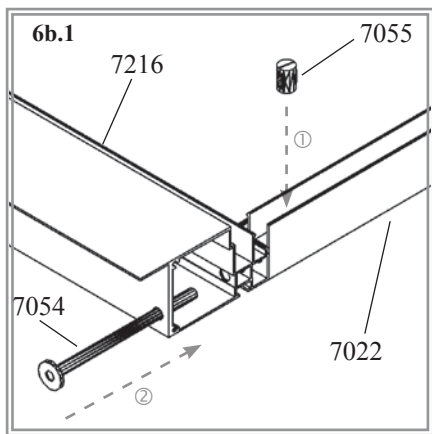
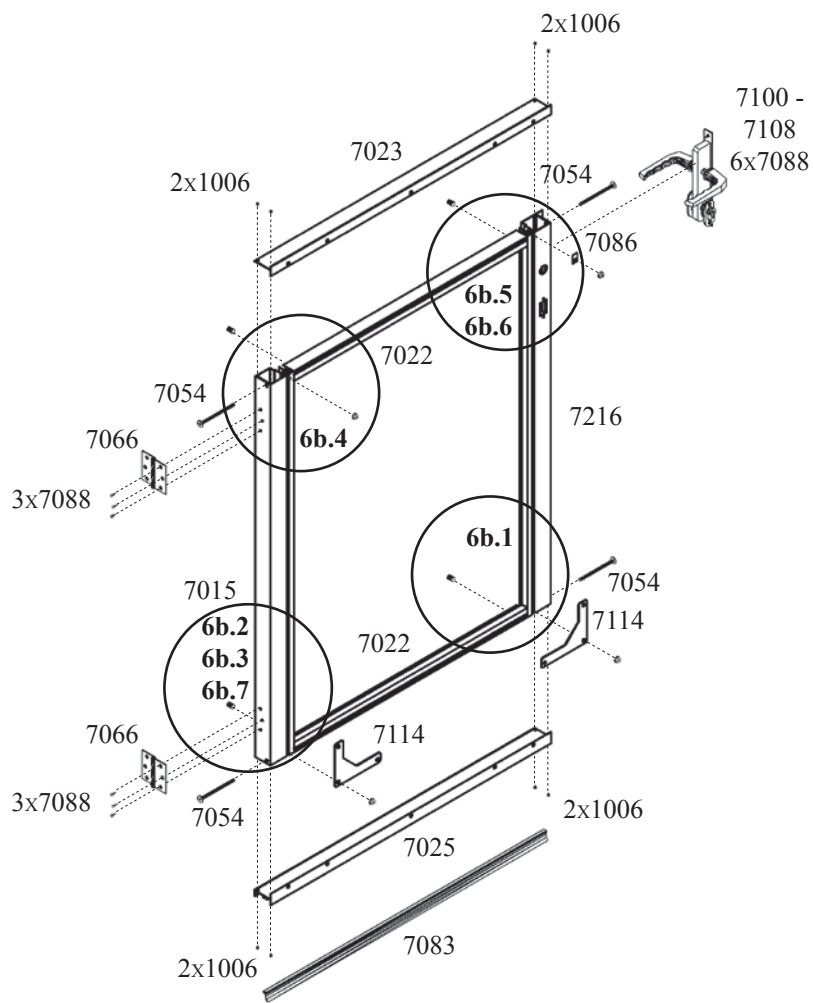

Alle modeller	
1006 x8	
7015 x1	
7022 x2	
7023 x1	
7025 x1	
7052 x4	
7053 x4	
7054 x4	
7055 x4	
7066 x2	
7083 x1	
7086 x1	
7088 x12	
7100 x1	
7101 x1	
7102 x1	
7103 x2	
7104 x2	
7106 x2	
7107 x1	
7108 x2	
7114 x2	
7216 x1	

ZEUS 2

NEDERSTE DØRDEL

BEMÆRK VENLIGST:

Isætning af glas i dørene beskrives i sektion 7c.

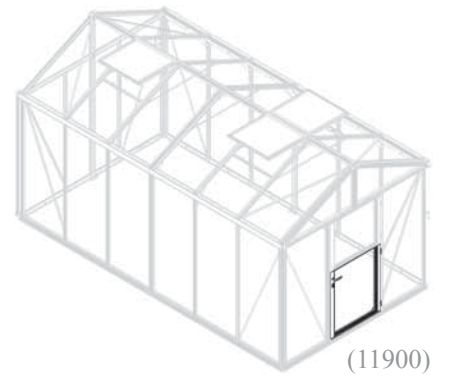

Monter to tombolte 7052 med møtrikker 7053 i hver af profilerne 7015 og 7216 (6b.2), (6b.4) og (6b5).

Som vist i 6b samles rammen til den nederste del af døren, der består af 7015, 7216 og 2 stk. 7022, ved hjælp af tværbøsning 7055 og samleskrue 7054, der føres gennem de forborede huller i 7022, (6b.1).







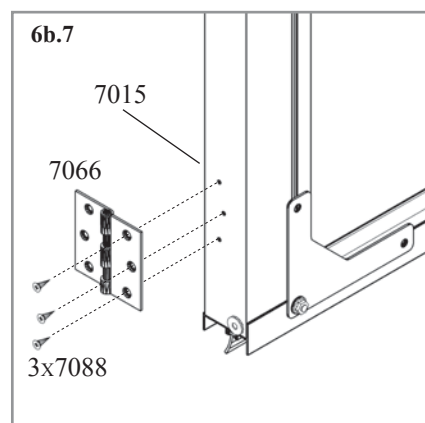
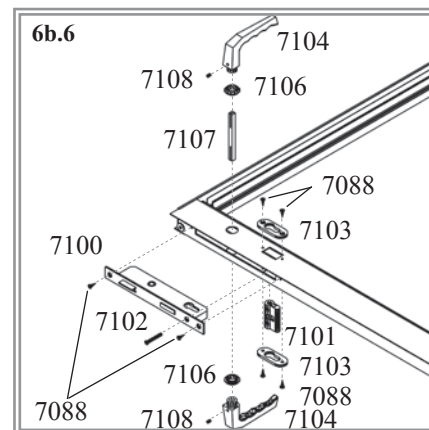
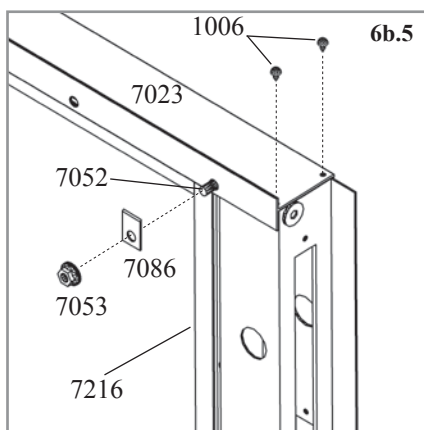

Monter afdækningsprofil 7025 forneden (6b.2) med 4 skruer 1006 og hjørnebeslag 7114. Tætningsliste 7083 føres ind i den nederste afdækningsprofil 7025 (6b.3).









Afdækningsprofil 7023 monteres foroven med 4 skruer 1006 og de tidligere monterede bolte 7052 og møtrikker 7053 (6b.4). I samme arbejdsgang monteres låseplade 7086 til 7023 ved hjælp af den formonterede bolt 7052 og møtrik 7053.

Dørlåsen 7100 – 7108 samles og fastspændes til 7216 ved hjælp af skruer 7088 (6b.6).

Ved hjælp af skruer 7088 fastspændes hængslerne 7066 til den lodrette dørprofil 7015 (6b.7).



7.1	POLYCARBONAT						ANTAL / MODEL				
	6 MM (TAG 10MM)		10 MM		16 MM		8100	10000	11900	13800	15700
	KODE	MM	KODE	MM	KODE	MM					
A 	3695711	725 x 1790	3695712	725 x 1790	3695713	725 x 1790	12	14	16	18	20
B 	3695726	725 x 1368	3695726	725 x 1368	3695727	710 x 1368	6	8	9	11	13
C 	3695736	725 x 699	3695736	725 x 699	3695737	710 x 691	2	2	3	3	3
D 	3695744	670 x 660	3695744	670 x 660	3695745	645 x 637	2	2	3	3	3
E 	3695751	725 x 966	3695752	725 x 966	3695753	725 x 966	1	1	1	1	1
F 	3695761	725 x 683	3695762	725 x 683	3695763	725 x 683	1	1	1	1	1
G 	3695771	1190x567/15	3695772	1190x567/15	3695773	1190x567/15	2	2	2	2	2
H 	3695781	1190x567/15	3695782	1190x567/15	3695783	1190x567/15	2	2	2	2	2
J 	3695791	435 x 1790	3695792	435 x 1790	3695793	435 x 1790	2	2	2	2	2
TOTAL							30	34	39	43	47

7.2	GLAS / POLYCARBONAT		ANTAL / MODEL				
	4 MM / 10MM		8100	10000	11900	13800	15700
	KODE	MM					
A 	367801	725 x 1790	12	14	16	18	20
B 	3695726	725 x 1368 x 10	6	8	9	11	13
C 	3695736	725 x 699 x 10	2	2	3	3	3
D 	3695744	670 x 660 x 10	2	2	3	3	3
E 	367805	725 x 966	1	1	1	1	1
F 	367806	725 x 683	1	1	1	1	1
G 	367807	1190x567/15	2	2	2	2	2
H 	367808	1190x567/15	2	2	2	2	2
J 	367809	435 x 1790	2	2	2	2	2
TOTAL			30	34	39	43	47

GLASPLAN

BEMÆRK VENLIGST:

Til dette trin i opbygningsprocessen bør der være 2 personer.

Ved isætning af glas og polycarbonat bør anvendes arbejds-handsker, ligesom vi anbefaler at anvende beskyttelsesbriller, sikkerhedssko og sikkerhedshjelm!

Bemærk den foreskrevne rækkefølge til isætning af glas: 7a – 7b og 7c som vist.

Den udvendige side af polycarbonatpladerne er forsynet med en plastfolie eller mærket på anden vis.

Start med at sortere glas og polycarbonatplader efter modeltype i henhold til oversigten i tabel (7.1) eller 7.2, inden montagen påbegyndes.



Den UV-beskyttede side af polycarbonatpladerne er påsat en tynd plastic-folie, eller der er trykt en tekst ved pladekanterne. Denne side SKAL vende udad. Fjern først folien, når pladerne er monteret, da der ellers ikke er synlig forskel på den udvendige og indvendige side af pladerne.

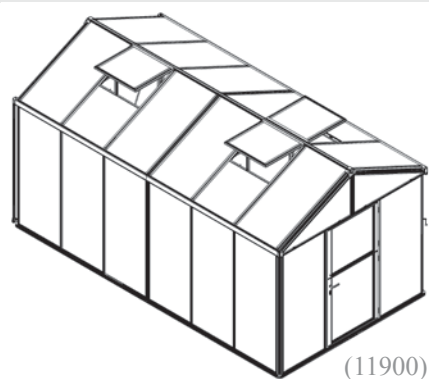

Glasplan

Model				
8100	10000	11900	13800	15700
A				<input type="checkbox"/>
12	14	16	18	20
B				<input type="checkbox"/>
6	8	9	11	13
C				<input type="checkbox"/>
2	2	3	3	3
E				<input type="checkbox"/>
1	1	1	1	1
F				<input type="checkbox"/>
1	1	1	1	1
G				<input type="checkbox"/>
2	2	2	2	2
H				<input type="checkbox"/>
2	2	2	2	2
J				<input type="checkbox"/>
2	2	2	2	2

(8100)

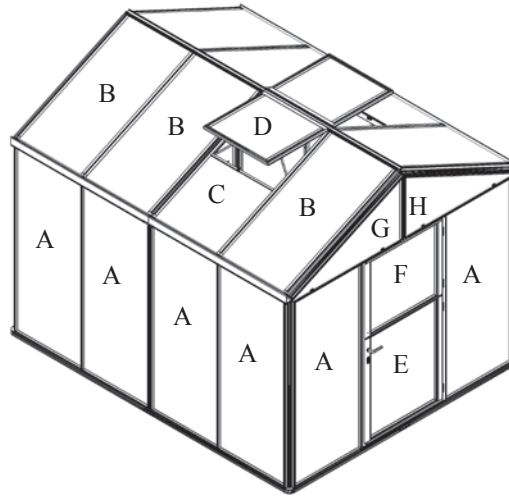

(10000)

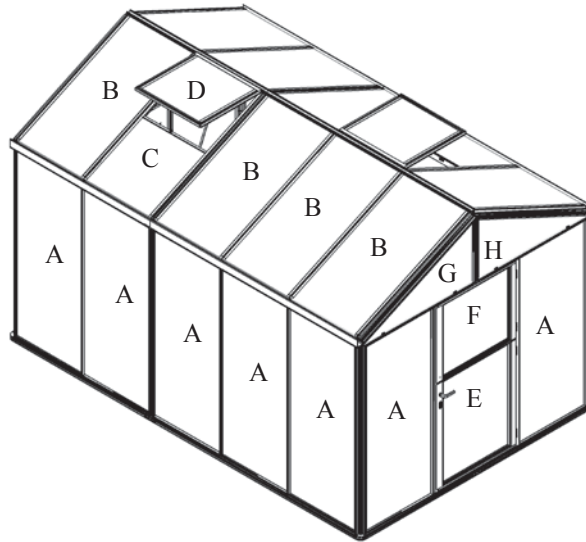

(11900)

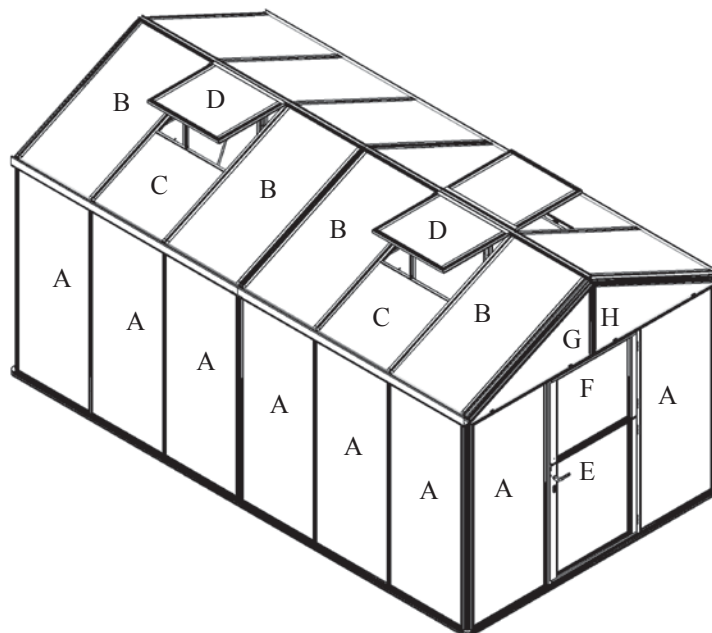

(13800)

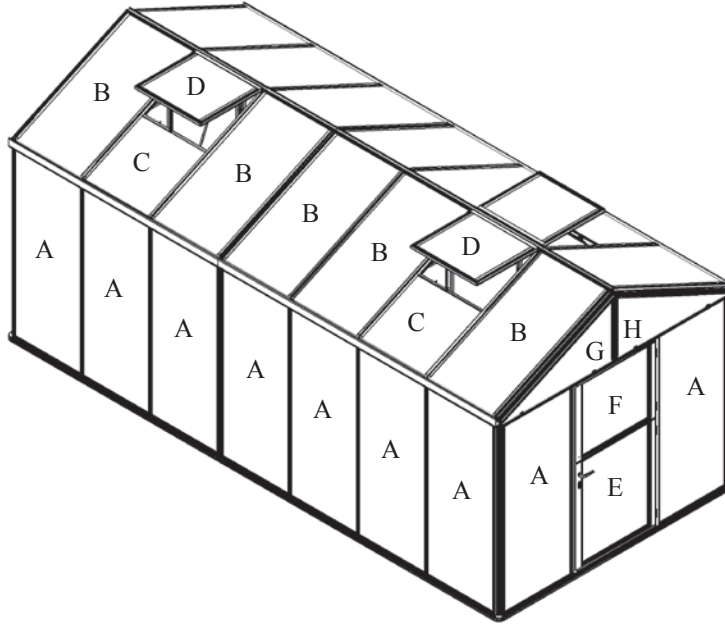

(15700)

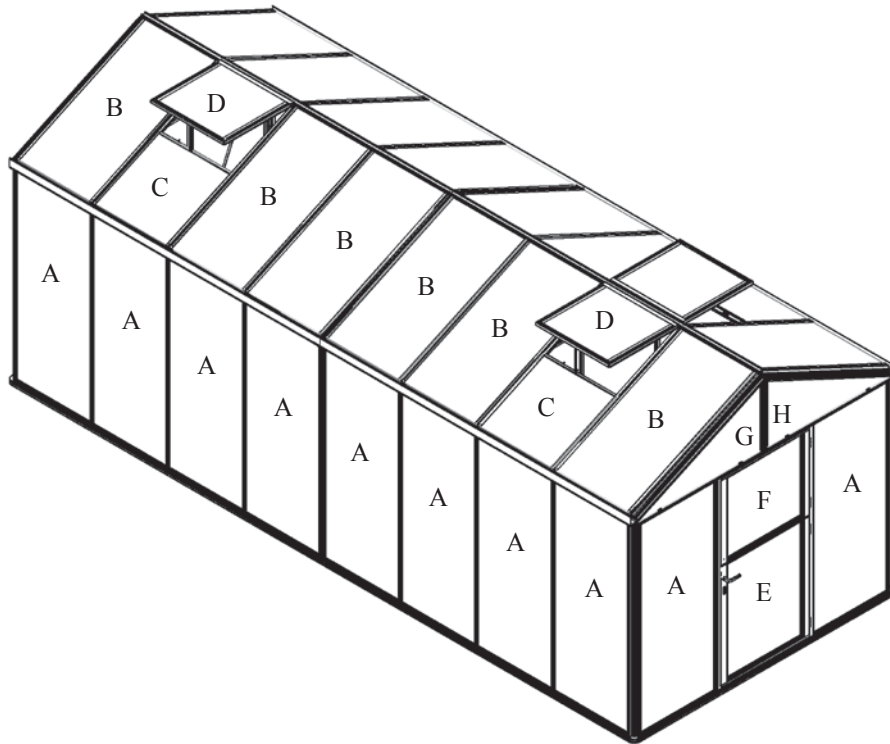

Baggavl – alle modeller

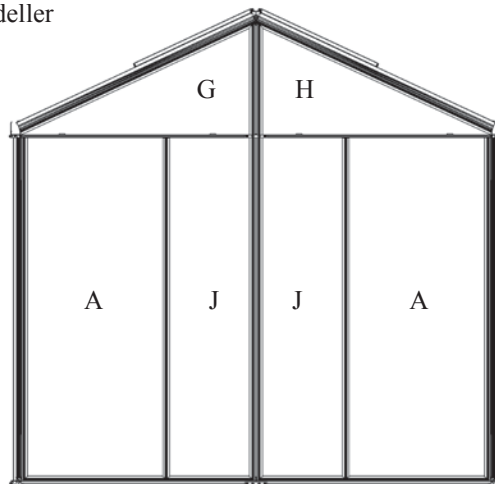

7a

(10000)

7a.1	TAGREM 1 – TAGREM 2	LÆNGDE
8100	7213-7213	1539 + 1539 mm
10000	7213-7214	1539 + 2283 mm
11900	7214-7214	2283 + 2283 mm
13800	7214-7215	2283 + 3027 mm
15700	7215-7215	3027 + 3027 mm

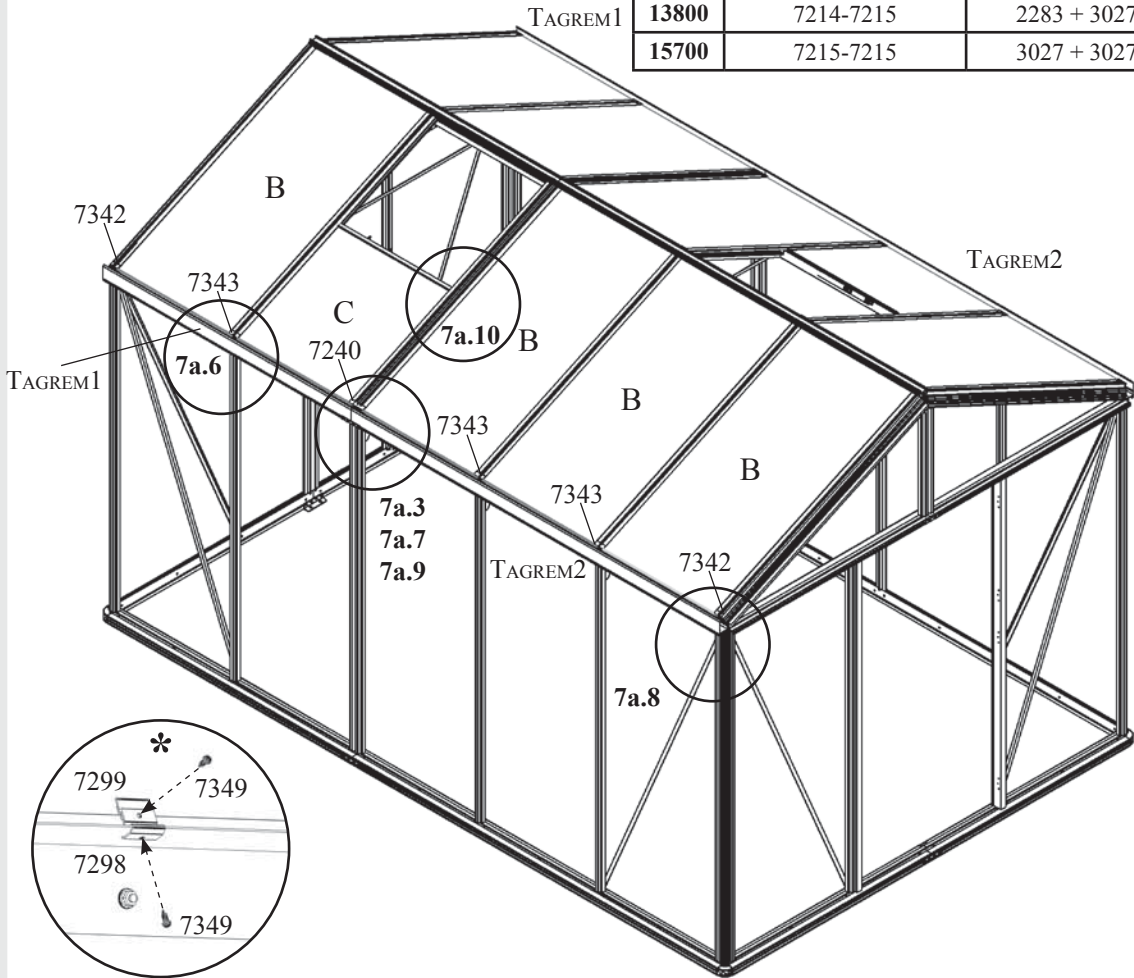

7a.2	POLYCARBONAT				ANTAL / MODEL				
	10 MM		16 MM		8100	10000	11900	13800	15700
	KODE	MM	KODE	MM					
B	3695726	725 x 1368	3695727	710 x 1368	6	8	9	11	13
C	3695736	725 x 699	3695737	710 x 691	2	2	3	3	3

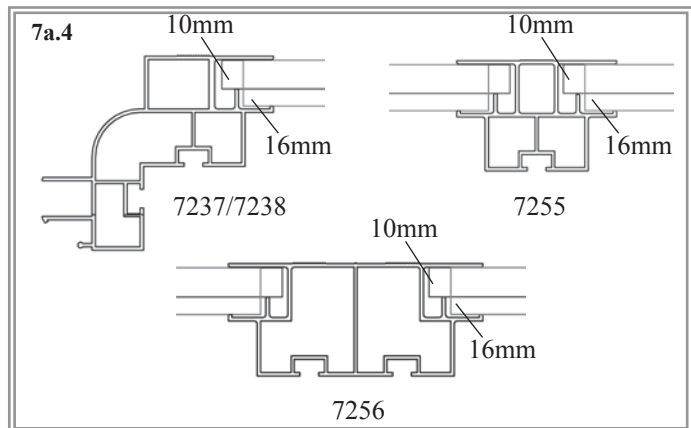
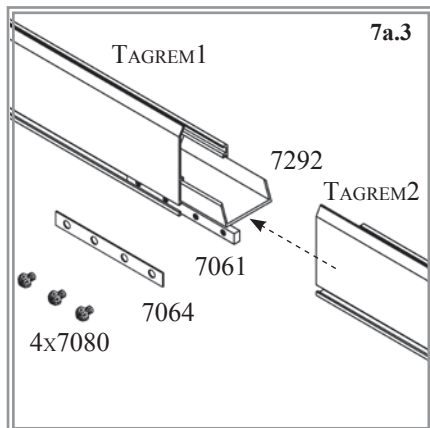

Model				
8100	10000	11900	13800	15700
7052				
8	10	12	14	16
7053				
8	10	12	14	16
7061				
2	2	2	2	2
7064				
2	2	2	2	2
7080				
8	8	8	8	8
7213				
4	2	0	0	0
7214				
0	2	4	2	0
7215				
0	0	0	2	4
7240				
2	2	2	2	2
7292				
2	2	2	2	2
7296				
8	10	12	14	16
7297				
8	10	12	14	16
7342				
4	4	4	4	4
7343				
4	6	8	10	12
7349				
34	42	50	58	66
7298*				
8	10	12	14	16
7299*				
8	10	12	14	16

ZEUS 2

ISÆTNING AF GLAS I TAGET / TAGRENDE (TAGREM)

BEMÆRK VENLIGST:

Til dette trin i opbygningsprocessen bør der være 2 personer – og meget gerne 3.

Ved isætning af glas og polycarbonat bør anvendes arbejdshandsker, ligesom vi anbefaler at anvende beskyttelsesbriller, sikkerhedssko og sikkerhedshjelm!

Den udvendige side af polycarbonatpladerne er forsynet med en plastfolie eller mærket på anden vis.

Klargør tagrenderne til slutmontage ved at forbinde tagrendeprofilerne i henhold til tabel (7a.1) med samlebeslagene 7061, laskeplade 7064 og bolte 7080 (7a.3). Kontroller, at plasticforbinder 7292 sidder centralt i forhold til samlingen.

Skub polycarbonatpladerne på plads i tagprofilerne som vist i (7a.4) og (7a.5), bemærk i (7a.4), at der anvendes forskellige spor til 10 mm og 16 mm polycarbonatplader.

Når to naboplader er på plads monteres tagpladestop 7240, 7342 eller 7343 i tagprofilerne ved at montere selvskærende skrue 7349 i de forborede huller (7a.6). Tagpladerne skal glide ned og have anslag mod disse tagpladestop.

Anbring afstandsstykke 7296 på den indvendige side af kanten af tagremmen (7a.7). Hvis der anvendes 10 mm polycarbonatplader skal afstandsstykke 7297 anbringes i rillen på 7296 således, at den støder an mod polycarbonatpladen. Afstandsstykket/stykkerne fastgøres ved hjælp af skrue 7349, der fastgøres i de forborede huller (7a.7) og (7a.9).

Ved 16 mm polycarbonatplader er det ikke nødvendigt at anvende afstandsstykke 7294 (7a.9b).

I tagsektionerne med ventilationsvinduer isættes polycarbonatpladerne C ved at lade den glide i sporet i profil 7294 (7a.10).

Læg en streng af neutral silikone i hele den forreste tagrems længde (7201 – 7206), (7a.8).

Til sidst vippe hele tagremmen/tagrenden ned på plads (7a.8) således at den støder an mod sideprofilerne. Fastspænd tagremmen/tagrenden ved hjælp af bolte 7052, der monteres udvendigt fra og møtrikker 7053, der monteres fra indvendig side (7a.9).

** NB!: Kondensdannelse kan ikke helt undgås i et drivhus med polycarbonat, men kondensdannelsen kan reduceres ved at udskifte kode nr. (7296 / 7297) med kode nr. (7298 / 7299). Dette vil forøge luftcirkulationen og dermed reducere kondensdannelse. Ved hjælp af skrue (7349) anbringes en (7298 / 7299) i midten af hver tagplade ned mod tagkanten.*

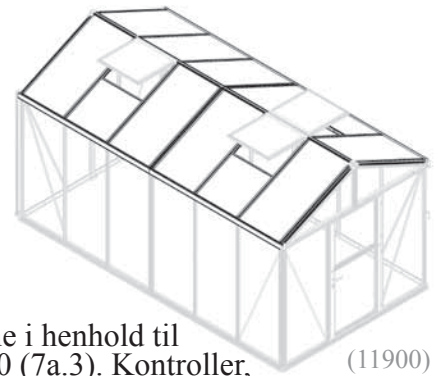

(11900)

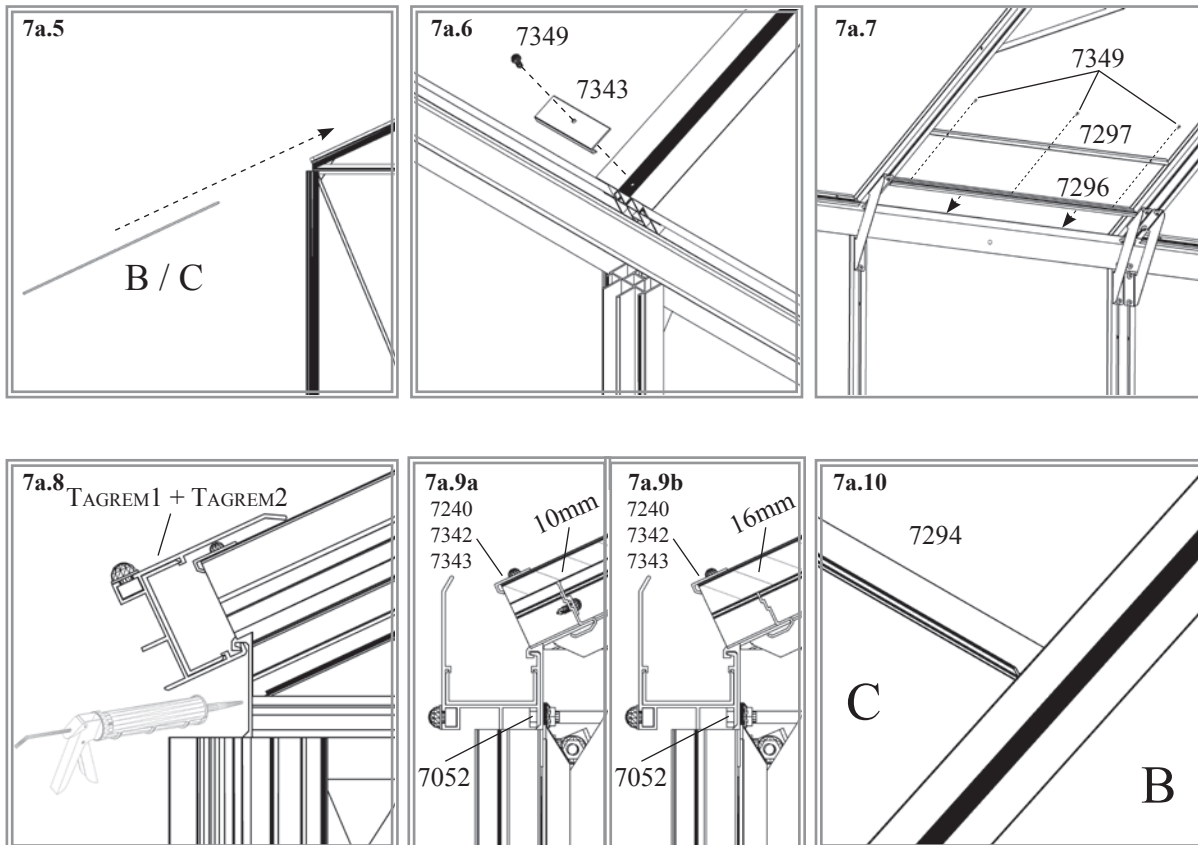

Isætning af glas i taget / tagrende (tagrem)

ZEUS 2

7b

(10000)

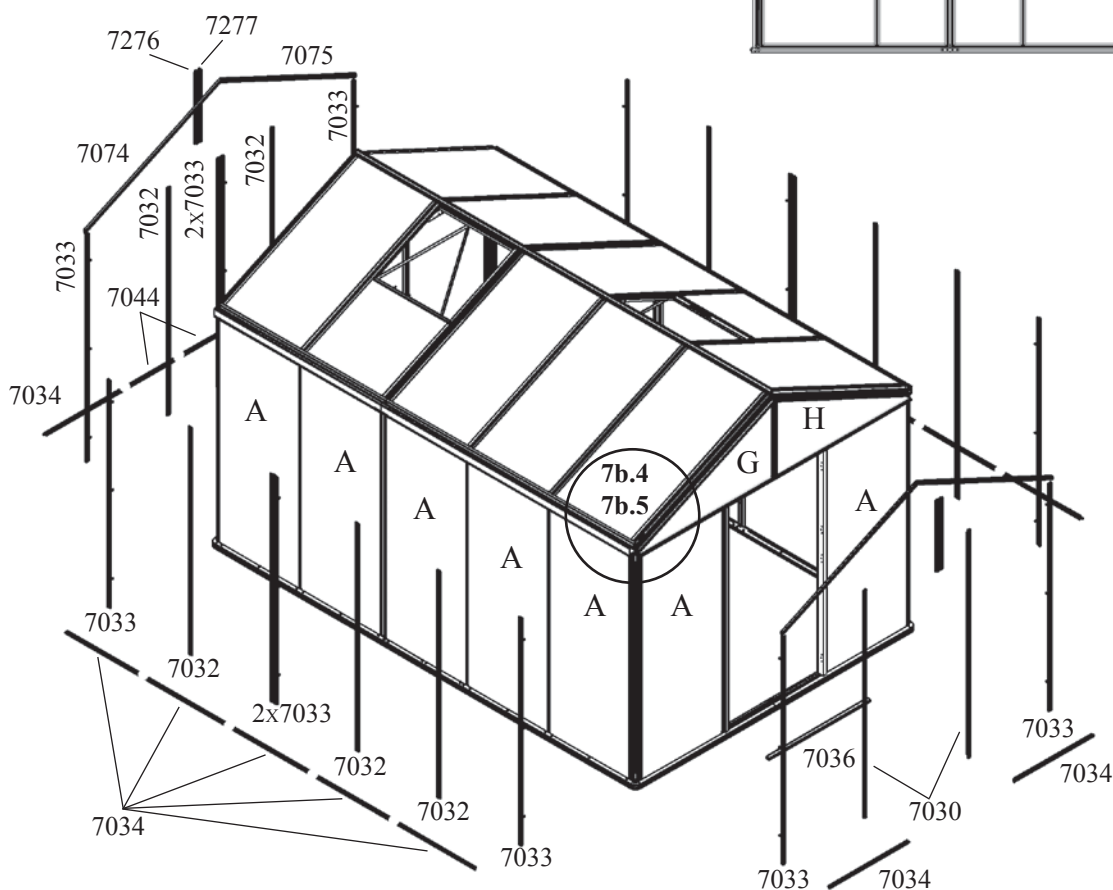
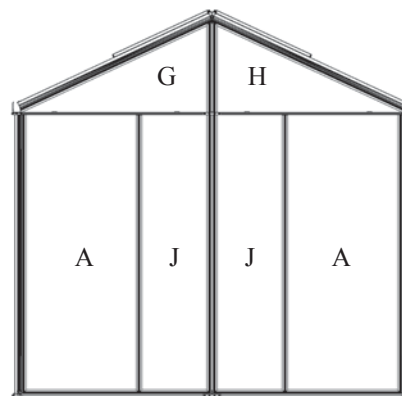
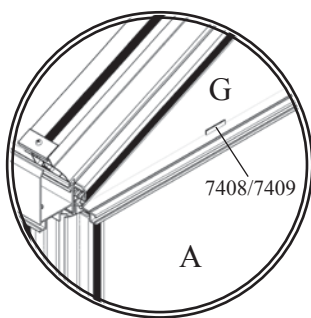

Model				
8100	10000	11900	13800	15700
6090				
1	1	1	1	1
7030				
2	2	2	2	2
7032				
6	8	10	12	14
7033				
14	14	14	14	14
7034				
12	14	16	18	20
7036				
1	1	1	1	1
7044				
2	2	2	2	2
7050				
126	138	150	162	174
7053				
130	142	154	166	178
7074				
2	2	2	2	2
7075				
2	2	2	2	2
7276				
2	2	2	2	2
7277				
2	2	2	2	2
7390				
4	4	4	4	4
7406				
14	16	18	20	22
7407				
14	16	18	20	22
7408				
8	8	8	8	8
7409				
8	8	8	8	8

7b.1	GLAS	POLYCARBONAT				ANTAL / MODEL					
		4 MM	6 MM	10 MM	16 MM	MM	8100	10000	11900	13800	15700
		KODE	KODE	KODE	KODE						
A		367801	3695711	3695712	3695713	725 x 1790	12	14	16	18	20
G		367807	3695771	3695772	3695773	1190x567/15	2	2	2	2	2
H		367808	3695781	3695782	3695783	1190x567/15	2	2	2	2	2
J		367809	3695791	3695792	3695793	435 x 1790	2	2	2	2	2

ISÆTNING AF GLAS I SIDERNE

BEMÆRK VENLIGST:

Til dette trin i opbygningsprocessen bør der være 2 personer – og meget gerne 3.

De bør altid bruge arbejdshandsker, når De arbejder med polycarbonatplader eller glas. Ved isætning af glas bør De også anvende beskyttelsesbriller, sikkerhedssko og hovedbeskyttelse (sikkerhedshjelm). Itugået glas udgør en sikkerhedsrisiko og bør bortskaffes med forsigtighed.

Bemærk den foreskrevne rækkefølge til isætning af glas.

Den udvendige side af polycarbonatpladerne er forsynet med en plastfolie eller mærket på anden vis.

Ved isætning af 4 mm glas skal der anvendes glaslister 6090, der monteres på aluminiumsprofilerne før glasset sættes. Ved isætning af polycarbonatplader er det ikke nødvendigt at anvende glasliste 6090.

Ved isætning af 4 mm glas eller 16 mm polycarbonat er det ikke nødvendigt at anvende afstandsstykker 7406 – 7409.

Start med at anbringe 4 bolte 7390 i bundlisten i døren 7036. Forbind 7036 med bundliste 7003 og 7004; dette gøres udefra i døråbningen.

Ved isætning af 4 mm glas skal glasliste 6090 anvendes. 6090 monteres på aluminiumsprofilerne før glasset sættes som vist i (7b.2).

Fastgørelseslisterne/dæklisterne kan anvendes til forskellige glas/pladetykkelser.

For at muliggøre dette, skal hovederne på bolte 7050 indføres i forskellige positioner i afdækningslisterne (7b.2). Klargør afdækningslisterne med tre bolte 7050 hver, som vist på ill. (7b.3). Ved dækliste 7044 skal der kun anvendes 2 bolte 7050.

Anbring et afstandsstykke (6 mm 7406 / 10 mm 7407) i midten / toppen af rude A eller J (7b.4). Anbring hver glas A eller J i rammen og monter de lodrette dæklister løst med møtrik 7053.

Løft glasset ca. 15 mm for at kunne forbinde dækliste 7034 og 7044 løst under ruden.

Anbring to afstandsstykker (6 mm 7408 / 10 mm 7409) på hver 7010 og 7011 (7b.5).

Anbring rude G og H i afstandsstykkerne og forbind løst dæklister 7074, 7075, 7276 og 7277. Kontroller, at drivhuset er i lod og vater overalt inden boltene og møtrikker spændes til.

Pas på ikke at overspænde bolte og møtrikker!



TIP: De lodrette dæklister monteres lettest ved at starte med at isætte den nederste bolt i hullet, derefter den midterste og endelig den øverste. Sørg for, at dæklisten fortsat rører ved bundlisten.

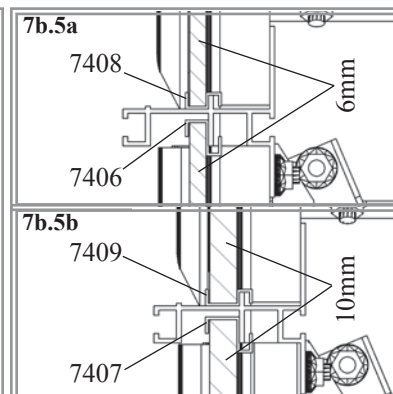
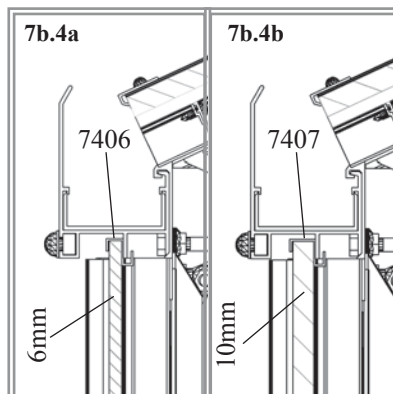
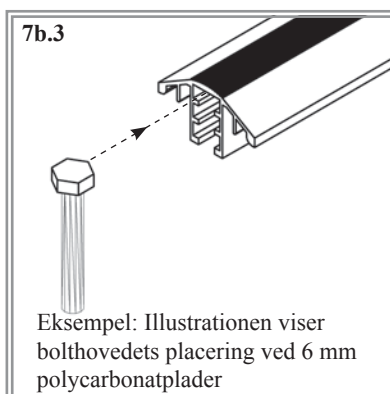
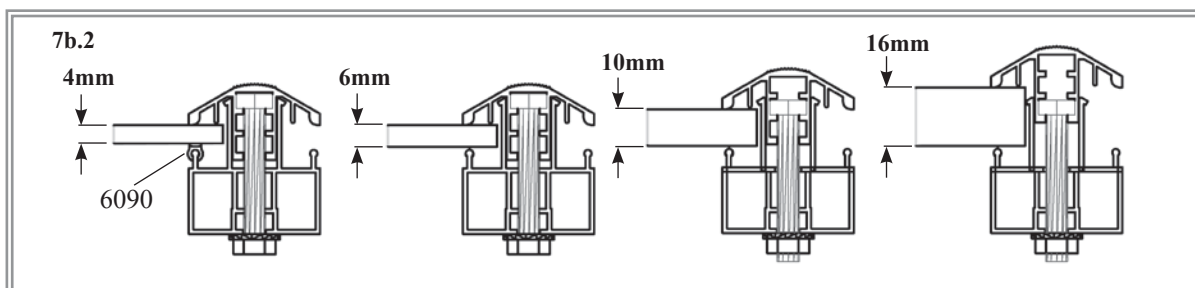
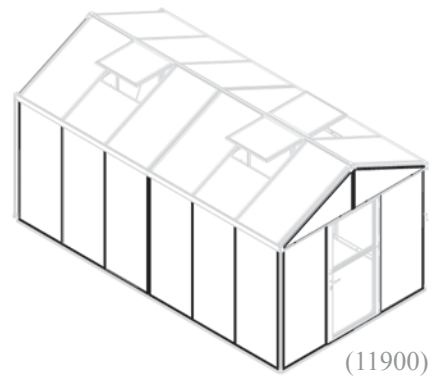

7c

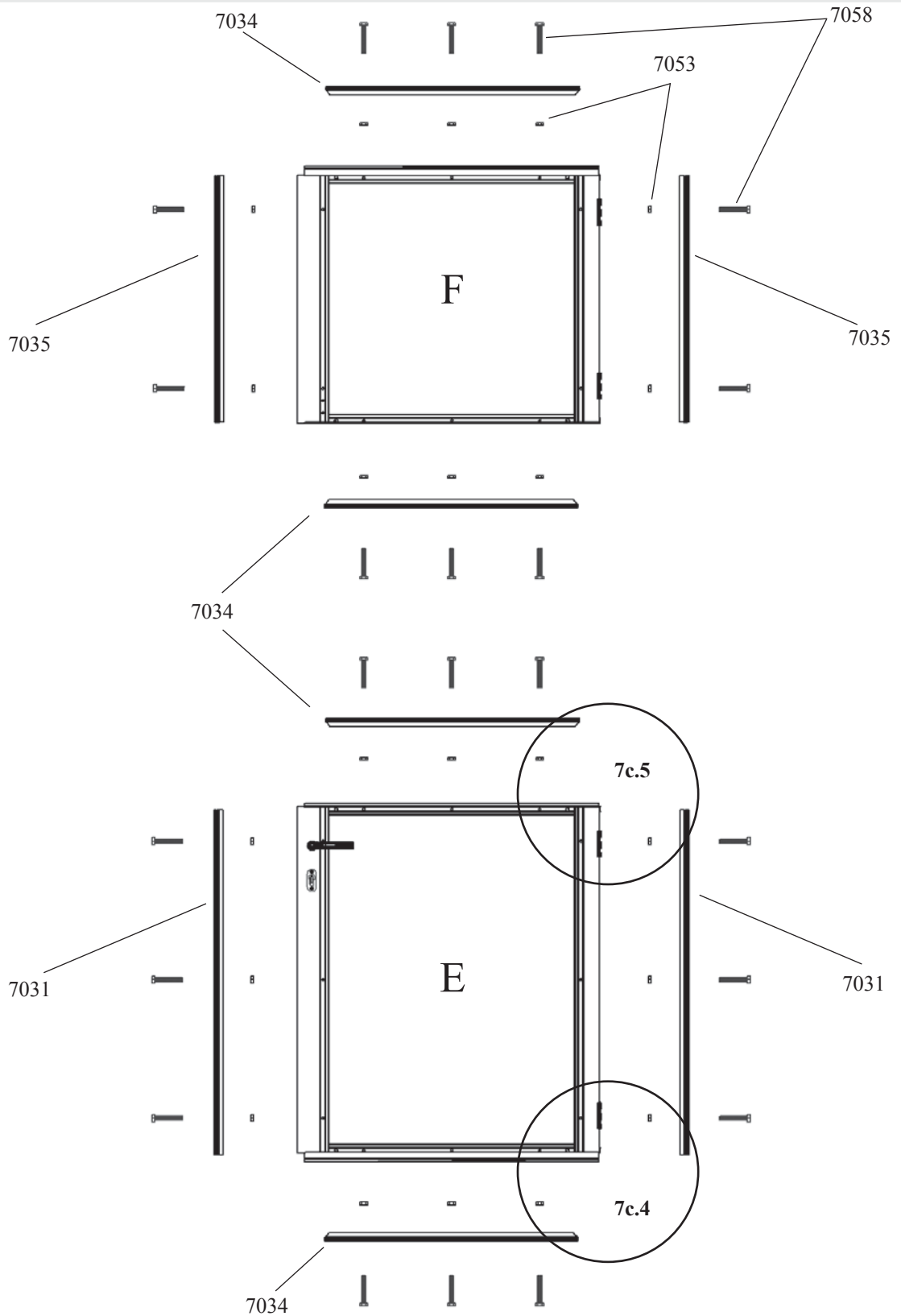

Alle modeller	
6090 x1	
7031 x2	
7034 x4	
7035 x2	
7053 x22	
7058 x22	
E x1	
F x1	

7c.1	GLAS	POLYCARBONAT				ANTAL / MODEL				
	4 MM	6 MM	10 MM	16 MM	MM	8100	10000	11900	13800	15700
	KODE	KODE	KODE	KODE						
E <input type="checkbox"/>	367805	3695751	3695752	3695753	725 x 966	1	1	1	1	1
F <input type="checkbox"/>	367806	3695761	3695762	3695763	725 x 683	1	1	1	1	1

ISÆTNING AF GLAS I DØR

BEMÆRK VENLIGST:

De bør altid bruge arbejdshandsker, når De arbejder med polycarbonatplader eller glas. Ved isætning af glas bør De også anvende beskyttelsesbriller, sikkerhedssko og hovedbeskyttelse (sikkerhedshjelm). Itugået glas udgør en sikkerhedsrisiko og bør bortskaffes med forsigtighed.

Bemærk den foreskrevne rækkefølge til isætning af glas.

Den udvendige side af polycarbonatpladerne er forsynet med en plastfolie eller mærket på anden vis.

Ved isætning af 4 mm glas skal glasliste 6090 først monteres på profilerne som vist i (7c.2 detalje 1).

Ved isætning af polycarbonatplader anvendes glaslisten ikke.

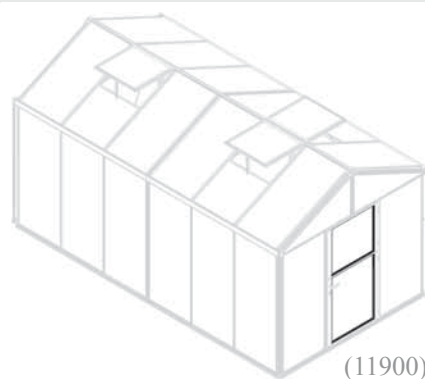

Fastgørelseslisterne/dæklisterne kan anvendes til forskellige glas/pladetykkelser. For at muliggøre dette, skal bolte 7058 indføres i forskellige positioner i afdækningslisterne (7c.2). Klarlæg afdækningslisterne med bolte 7058 som vist på ill. (7c.3).

Anbring glassene / polycarbonatpladerne i aluminiumsrammen.





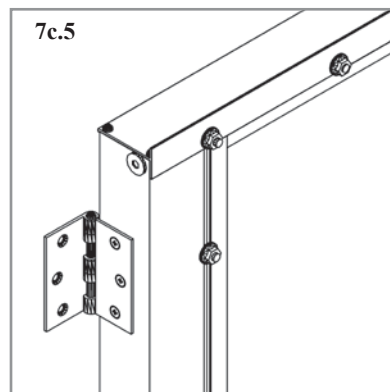
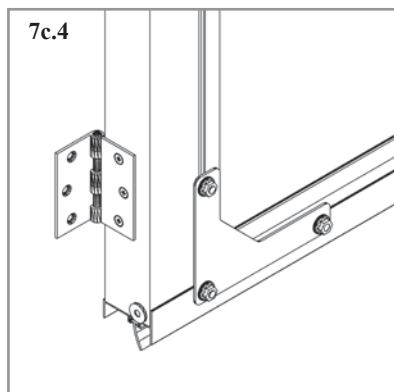
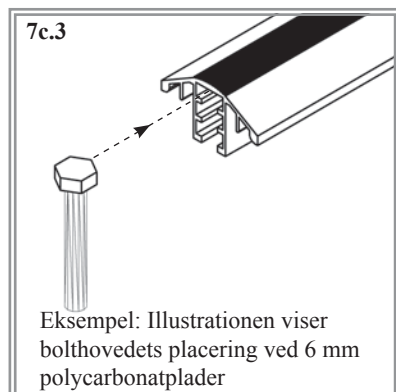
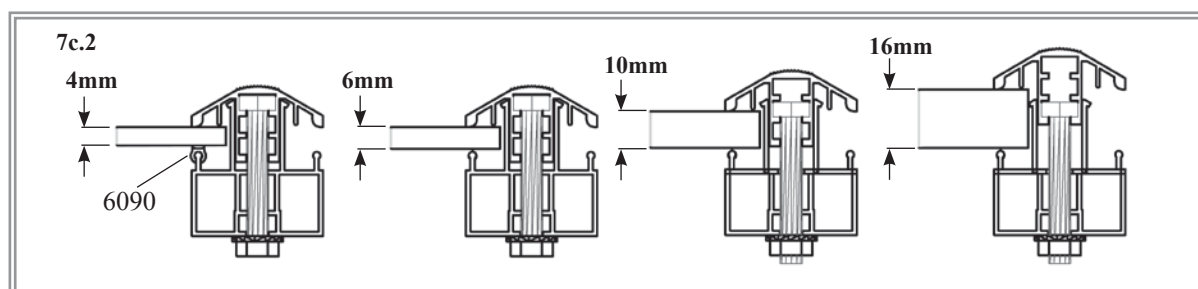



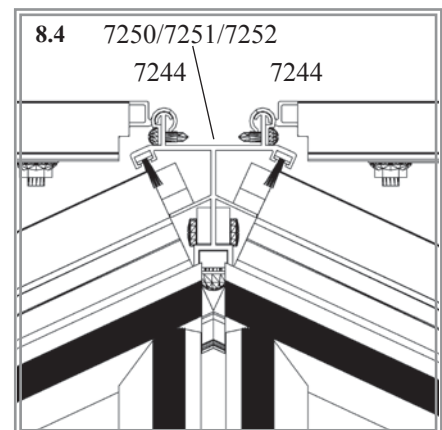
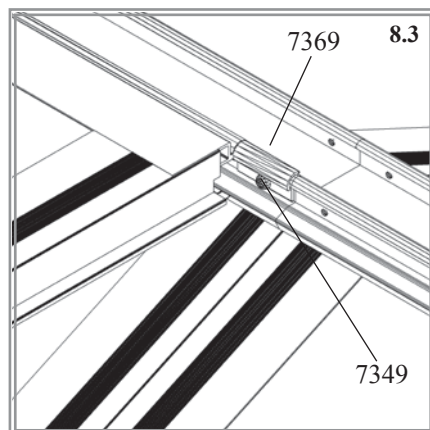
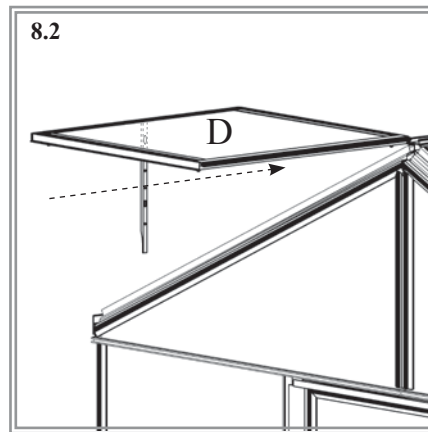
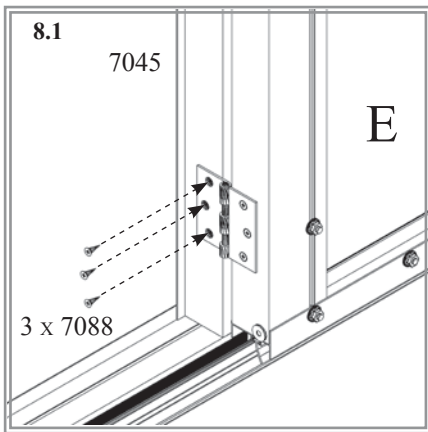
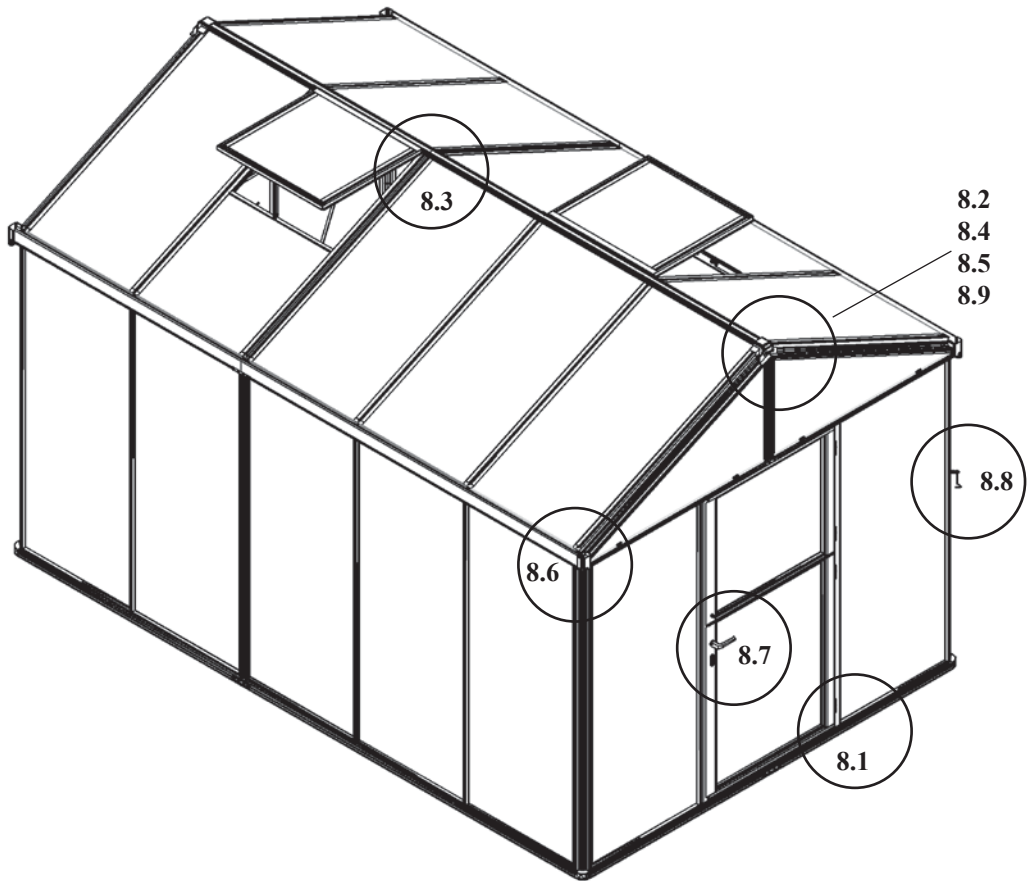



Placér dæklisterne og spænd dem løst fast med møtrik 7053.

Kontroller, at dørene er i vinkel, før alle bolte og møtrikker spændes til **uden at overspænde**.



(10000)



Model				
8100	10000	11900	13800	15700
7053 				
1	1	1	1	1
7056 				
4	4	4	4	4
7088 				
12	12	12	12	12
7111 				
1	1	1	1	1
7112 				
1	1	1	1	1
7113 				
1	1	1	1	1
7266 				
2	2	2	2	2
7349 				
4	4	6	6	6
7369 				
4	4	6	6	6
7370 				
2	2	2	2	2
7371 				
2	2	2	2	2
7399 				
1	1	1	1	1

FÆRDIGGØRELSE

BEMÆRK VENLIGST:

Kontroller, at drivhuset er i lod og vater og at alle bolte og møtrikker er monteret korrekt, at de har anslag og er spændte. Efter ca. 14 dage kontrolleres, om møtrikkerne har fast hold, ellers efterspændes uden at overspænde

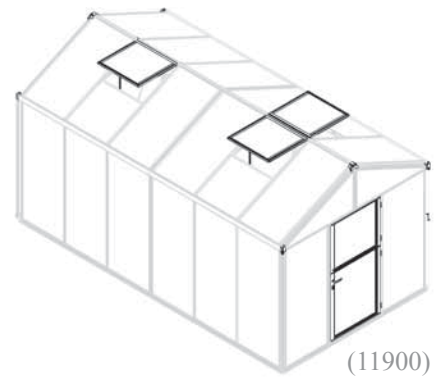

(11900)

Fastgør både den øverste og den nederste dørdel (samlet i trin 6a og 6b) til dørrammen 7045 ved hjælp af de selvskærende skruer 7088, se (8.1).

Skub ventilationsvinduerne på plads ved at lade disse glide ind i sporet på tagryggen, se (8.2). Fastgør vinduesstop 7369 ved at isætte selvborende skruer 7349 i de forborede huller på begge sider af tagvinduet (8.3), (8.4).

Monter tagrygafdækningen 7266 i begge ender af tagryggen med 2 selvskærende skruer 7056 som vist i (8.5).

Pres afløbsstuderne 7271 og 7270 på plads ind i tagrenderne 7213/7214 og 7215 (8.7).

☝ Tip: Det kan være en hjælp forsigtigt at trække tagrendeprofilen lidt væk fra drivhuset, så åbningen til indpresning af studsene til nedløbsrøret bliver større.

Monter øsken 7111 på dørprofil 7018 i det forborede hul som vist i 8.7. Husk at montere afstandsbøsning 7112.

Monter bolt 7399 i sporet på hjørnestolpe 7236 og fastgør den løst ved hjælp af møtrik 7053. Juster højden på 7399/7053, så højden passer til øsken 7111 på dørprofil 7018. Spænd 7399 fast med 7053.

Monter dørkrog 7113 på bolt 7399, se (8.8).

Det anbefales at lægge en streng neutral silikone udvendigt ved tagrygsamlingen og ligeledes indvendigt tre steder i hver gavl, hvor tagryggen støder an mod gavlen, se (8.9). NB! Silikone indgår ikke i leverancen.



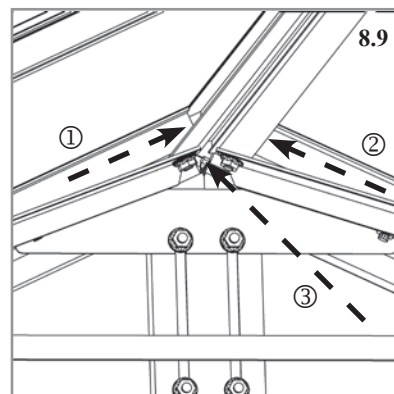
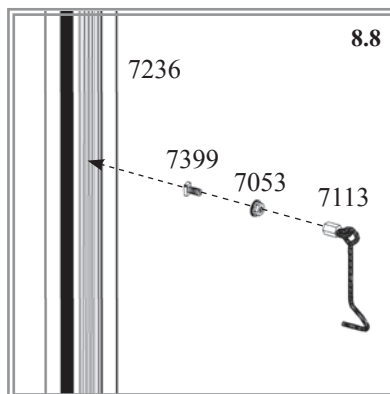
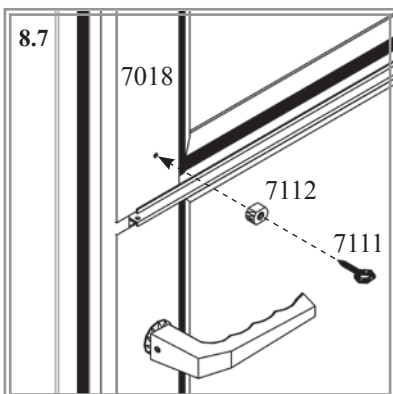
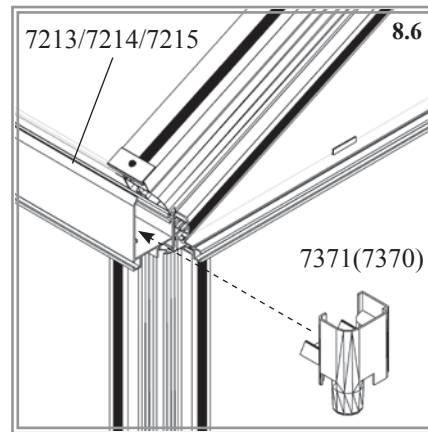
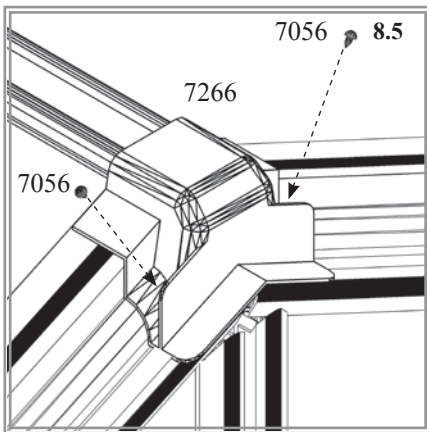





Den vedlagte selvklæbende identifikationsetiket anbringes indvendigt i drivhuset – f.eks. indvendig på døren eller lign. Oplysningerne på etiketten vil gøre det meget lettere for Dem at fremskaffe reservedele, såfremt dette skulle blive aktuelt.



Færdiggørelse

ZEUS 2

Alle modeller

1002 x2	
1006 x2	
1402 x2	
1403 x2	
1405 x2	
1409 x2	
1412 x2	
1415 x2	

(11900)

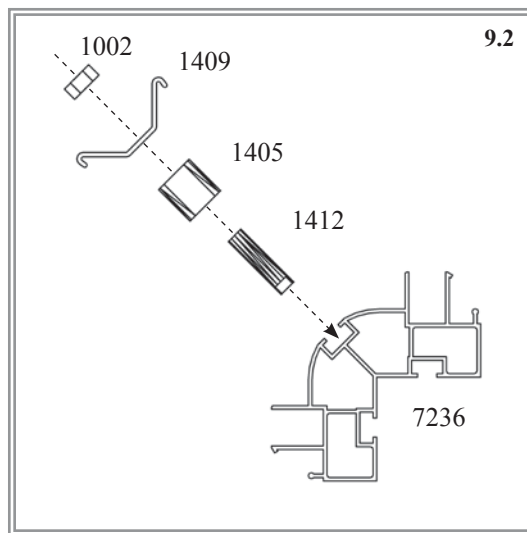
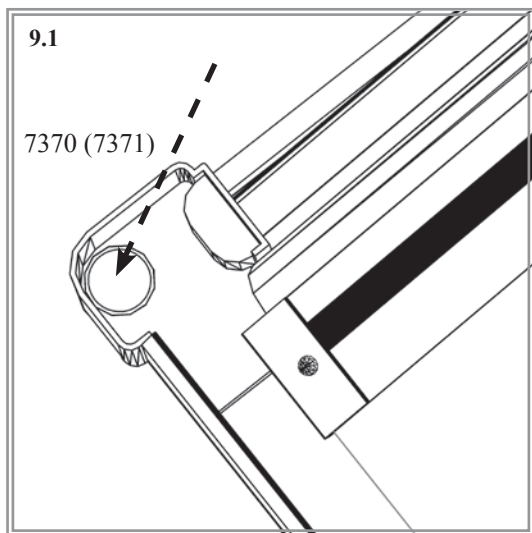
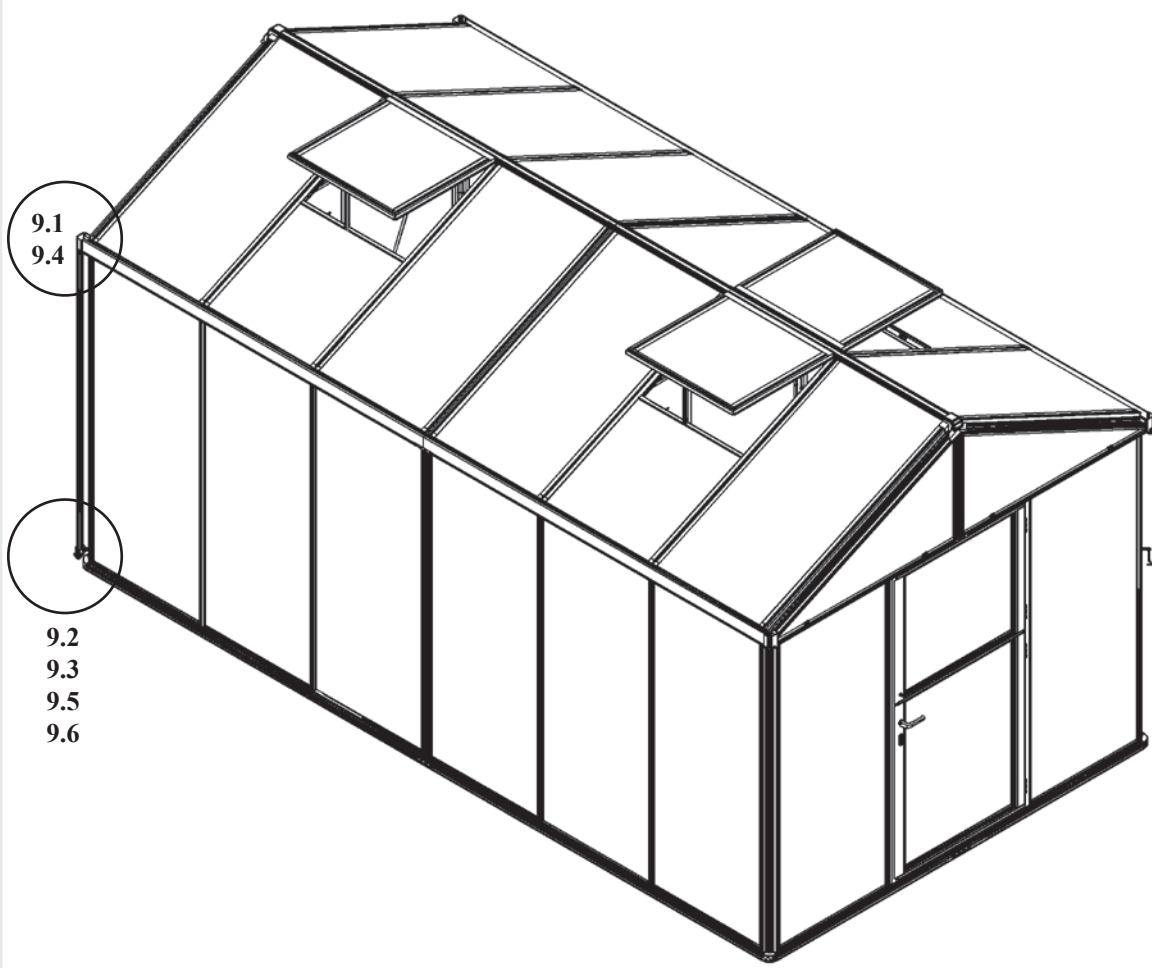

NEDLØBSRØR

BEMÆRK VENLIGST:

Vi anbefaler brug af arbejdshandsker og beskyttelsesbriller.

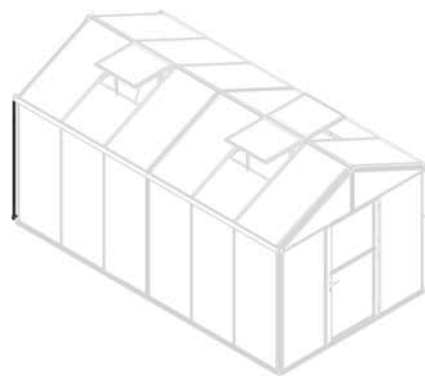

I den ende af drivhuset, hvor De ønsker at placere Deres nedløbsrør bores det formarkerede hul i (7370) og (7371) op med et bor max. Ø 25 mm, se (9.1).

Indsæt en bolt med tilfilet hovede (1412) i bunden af boltsporet i hjørnestolpe (7236) og monter bøsning (1405) og beslag (1409) med møtrik (1002) på begge sider af drivhuset, se (9.2).

Klem bøjning (1402) fast på nederste del af nedløbsrøret (1415), se (9.3), og klem derefter røret op omkring studsene til nedløbsrøret (7370) eller (7371), se (9.4).

Klem beslag (1403) fast rundt om nedløbsrøret og pres derefter (1403) således at klembeslaget får greb i flangen på beslag (1409), se (9.5).

Isæt skrue (1006) til fastholdelse af nedløbsrøret, se (9.6).

Vi ønsker Dem god arbejdslyst og håber, at De får rigtig mange gode stunder med og i Deres Vitavia drivhus.

Med venlig hilsen

OPJ A/S

Nedløbsrør

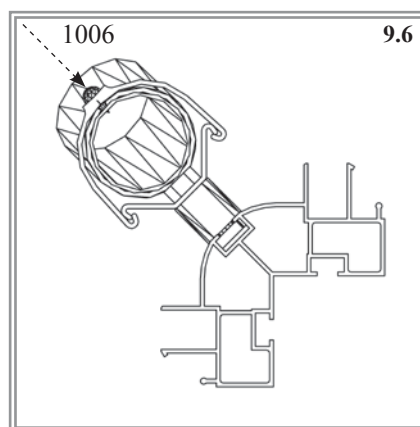
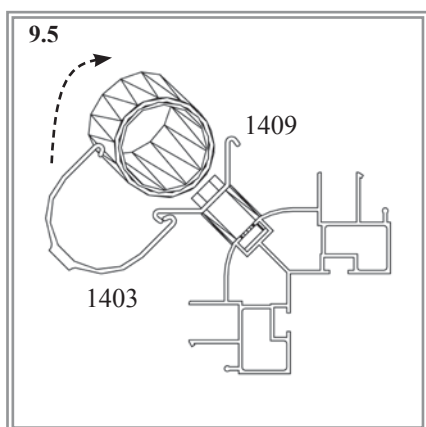
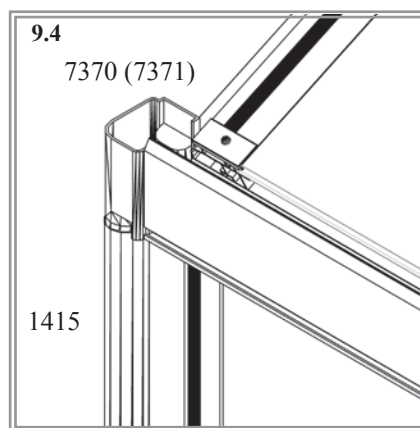
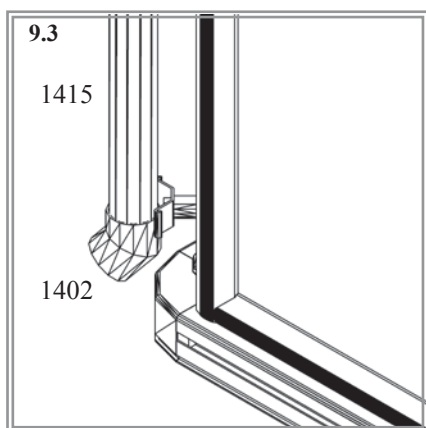



E.P.H. Schmidt u. Co. GmbH
Hoefkerstrasse 30
44149 Dortmund
Postfach 170163
44060 Dortmund
Deutschland
Tel.: +49 231 941655 0
Fax: +49 231 941655 99
www.eph-schmidt.de
verkauf@eph-schmidt.de

OPJ A/S
Volderslevvej 36 A
5260 Odense S
Danmark
Tel.: +45 66 15 10 30
Fax: +45 66 15 00 84
www.opj.dk
opj@opj.dk